

Specification for Drill Pipe

API SPECIFICATION 5D
FOURTH EDITION, AUGUST 1999

EFFECTIVE DATE: JANUARY 30, 2000



**Helping You
Get The Job
Done Right.SM**

Specification for Drill Pipe

Upstream Segment

API SPECIFICATION 5D
FOURTH EDITION, AUGUST 1999
EFFECTIVE DATE: JANUARY 30, 2000



**Helping You
Get The Job
Done Right.SM**

SPECIAL NOTES

API publications necessarily address problems of a general nature. With respect to particular circumstances, local, state, and federal laws and regulations should be reviewed.

API is not undertaking to meet the duties of employers, manufacturers, or suppliers to warn and properly train and equip their employees, and others exposed, concerning health and safety risks and precautions, nor undertaking their obligations under local, state, or federal laws.

Information concerning safety and health risks and proper precautions with respect to particular materials and conditions should be obtained from the employer, the manufacturer or supplier of that material, or the material safety data sheet.

Nothing contained in any API publication is to be construed as granting any right, by implication or otherwise, for the manufacture, sale, or use of any method, apparatus, or product covered by letters patent. Neither should anything contained in the publication be construed as insuring anyone against liability for infringement of letters patent.

Generally, API standards are reviewed and revised, reaffirmed, or withdrawn at least every five years. Sometimes a one-time extension of up to two years will be added to this review cycle. This publication will no longer be in effect five years after its publication date as an operative API standard or, where an extension has been granted, upon republication. Status of the publication can be ascertained from the API Upstream Segment [telephone (202) 682-8000]. A catalog of API publications and materials is published annually and updated quarterly by API, 1220 L Street, N.W., Washington, D.C. 20005.

This document was produced under API standardization procedures that ensure appropriate notification and participation in the developmental process and is designated as an API standard. Questions concerning the interpretation of the content of this standard or comments and questions concerning the procedures under which this standard was developed should be directed in writing to the general manager of the Upstream Segment, American Petroleum Institute, 1220 L Street, N.W., Washington, D.C. 20005. Requests for permission to reproduce or translate all or any part of the material published herein should also be addressed to the general manager.

API standards are published to facilitate the broad availability of proven, sound engineering and operating practices. These standards are not intended to obviate the need for applying sound engineering judgment regarding when and where these standards should be utilized. The formulation and publication of API standards is not intended in any way to inhibit anyone from using any other practices.

Any manufacturer marking equipment or materials in conformance with the marking requirements of an API standard is solely responsible for complying with all the applicable requirements of that standard. API does not represent, warrant, or guarantee that such products do in fact conform to the applicable API standard.

All rights reserved. No part of this work may be reproduced, stored in a retrieval system, or transmitted by any means, electronic, mechanical, photocopying, recording, or otherwise, without prior written permission from the publisher. Contact the Publisher, API Publishing Services, 1220 L Street, N.W., Washington, D.C. 20005.

FOREWORD

This edition of Spec 5D supersedes the third edition dated August 1, 1992, and includes items approved by letter ballot through June 1998. The first edition of Spec 5D superseded the thirty-ninth edition of Specification 5A and the fifteenth edition of Specification 5AX. Spec 5D is a combination of the drill pipe requirements detailed in the above editions of the discontinued Specifications 5A and 5AX.

This specification is under the jurisdiction of the API Committee on Standardization of Tubular Goods. The purpose of this specification is to provide standards for drill pipe suitable for use in drilling and producing operations. The tables on drill pipe were prepared in cooperation with the API Committee on Standardization of Drilling and Servicing Equipment.

API publications may be used by anyone desiring to do so. Every effort has been made by the Institute to assure the accuracy and reliability of the data contained in them; however, the Institute makes no representation, warranty, or guarantee in connection with this publication and hereby expressly disclaims any liability or responsibility for loss or damage resulting from its use or for the violation of any federal, state, or municipal regulation with which this publication may conflict.

Suggested revisions are invited and should be submitted to the general manager of the Upstream Segment, American Petroleum Institute, 1220 L Street, N.W., Washington, D.C. 20005.

Attention Users: Portions of this publication have been changed from the previous edition of Specification 5D. The locations of changes have been marked with a bar in the margin, as shown to the left of this paragraph. In some cases the changes are significant, while in other cases the changes reflect minor editorial adjustments. The bar notations in the margins are provided as an aid to users as to those parts of this publication that have been changed from the previous edition, but API makes no warranty as to the accuracy of such bar notations.

This standard shall become effective on the date printed on the cover but may be used voluntarily from the date of distribution.

INFORMATION TO BE SUPPLIED BY THE PURCHASER

When inquiring or placing orders for drill pipe to be manufactured in accordance with API Spec 5D, the purchaser should specify the following on the purchase order:

Specification API Spec 5D
 Quantity

Internal-upset, external-upset or internal-external-upset (for welding)..... 9.1, Table 1
 Size (outside diameter) Table 1
 Weight per foot or wall thickness Table 1
 Grade..... Table 1
 Range length 8.5, Table 9
 Seamless..... 4.1
 Delivery date and shipping instructions
 Inspection by purchaser 10.1, 10.2

The purchaser should also state on the purchase order the requirements concerning the following stipulations, which are optional with the purchaser:

Heat treatment of drill pipe 4.2
 Heat and supplementary analyses..... 5.2, 5.3
 Pipe coatings 11.6
 Markings in metric units 11.2.3, 11.2.4, 11.2.6
 Drill pipe with special threads or end finish..... 9.1
 Pipe ends Section 9
 Marking requirements..... 11.1
 Supplementary Requirements
 SR2—Nondestructive Inspection (N5 Notch or 1/16-in. Hole) Appendix B
 SR15—Test Certificates for Oil Country Tubular Goods Appendix B
 SR19—Charpy V-Notch Impact Toughness Testing of Group 1 (Grade E-75) Drill Pipe..... Appendix B
 SR20—Alternate Low Temperature Charpy V-Notch Impact Toughness Testing of Group 1 (Grade E-75) and Group 3 (Grades X-95, G-105, and S-135) Drill Pipe..... Appendix B
 Monogram Marking* D.2—Appendix D

*Users of this specification should note that there is no longer a requirement for marking a product with the API monogram. The American Petroleum Institute continues to license use of the monogram on products covered by this specification but it is administered by the staff of the Institute separately from the specification. The policy describing use of the monogram is contained in Appendix D, herein. No other use of the monogram is permitted. Licensees may mark products in conformance with Appendix D or Section 11 and Nonlicensees may mark products in conformance with Section 11.

SPECIAL NOTE:

NOTHING IN THIS SPECIFICATION SHOULD BE INTERPRETED AS INDICATING A PREFERENCE BY THE COMMITTEE FOR ANY MATERIAL OR PROCESS OR AS INDICATING EQUALITY BETWEEN THE VARIOUS MATERIALS OR PROCESSES. IN THE SELECTION OF MATERIALS AND PROCESSES, THE PURCHASER MUST BE GUIDED BY HIS EXPERIENCE AND BY THE SERVICE FOR WHICH THE PIPE IS INTENDED.

CONTENTS

	Page
1 SCOPE	1
1.1 Coverage	1
1.2 Retention of Records	2
1.3 Testing Equipment	2
1.4 Special Processes	2
1.5 Certification	2
2 REFERENCES	2
2.1 General	2
2.2 Requirements	2
2.3 Equivalent Standards	2
2.4 Referenced Standards	3
3 DEFINITIONS	3
4 PROCESS OF MANUFACTURE	3
4.1 General	3
4.2 Heat Treatment	3
4.3 Pipe Material	3
4.4 Lot Definition—Groups 1 and 3	3
4.5 Traceability	4
5 CHEMICAL COMPOSITION	4
5.1 Chemical Requirements	4
5.2 Heat Analyses	4
5.3 Product Analyses	4
5.4 Recheck Product Analyses—All Groups	4
6 MECHANICAL PROPERTIES REQUIREMENTS	4
6.1 Tensile Properties	4
6.2 Yield Strength	4
6.3 Longitudinal Impact Requirements	4
6.4 Energy Requirements, Longitudinal Charpy Impact Tests	7
6.5 Alternate Low Temperature Energy Requirements	7
7 TESTING	7
7.1 Tensile Tests	7
7.2 Chemical Analysis	8
7.3 Longitudinal Impact Tests	8
7.4 Dimensional and Weight Tests	9
8 REQUIREMENTS FOR DIMENSIONS, WEIGHTS, LENGTHS, AND DEFECTS	10
8.1 Dimensions and Weights	10
8.2 Diameter	10
8.3 Wall Thickness	10
8.4 Weight	10
8.5 Length	10
8.6 Straightness	10
8.7 Drift Requirements	10
8.8 Imperfections and Defects	12
9 PIPE ENDS	15
9.1 General	15
10 PIPE INSPECTION	15
10.1 General	15
10.2 Inspection Requirements	15
10.3 Pipe Inspection Coverage	15

	Page
10.4 Pipe Body Wall Thickness Verification	16
10.5 Visual Inspection	16
10.6 Standard Procedure for Inspection	16
10.7 Reference Standards	16
10.8 Automated Inspection System Signal Evaluation	16
10.9 Records Verifying System Capability	16
10.10 Certification and Qualification of Personnel	17
10.11 Evaluation of Indications (Prove-up)	17
10.12 Disposition	17
11 MARKING AND COATINGS	18
11.1 General	18
11.2 Pipe Markings	18
11.3 Die-Stamped Markings	19
11.4 Paint-Stenciled Markings	19
11.5 Pipe Processor Markings	19
11.6 Coatings	19
12 MINIMUM FACILITY REQUIREMENTS FOR VARIOUS CATEGORIES OF MANUFACTURERS	19
12.1 Pipe Mill	19
12.2 Processor	19
APPENDIX A METRIC TABLES	21
APPENDIX B SUPPLEMENTARY REQUIREMENTS	25
APPENDIX C PURCHASER INSPECTION	29
APPENDIX D USE OF API MONOGRAM	31
APPENDIX M METRIC CONVERSION PROCEDURE	33

Figures

1 Tensile Test Specimens	8
2 Impact Test Specimen Orientation—Longitudinal Specimens	9
3 Upset Drill Pipe for Weld-on Tool Joints (Group 1)	12
4 Upset Drill Pipe for Weld-on Tool Joints (Group 3)	12
5 Saddle Gage for Measuring Eccentricity of Drill Pipe	14
SR-2 Reference Standard	25

Tables

1 API Drill Pipe List	1
2 Retention of Records	2
3 Chemical Requirements	4
4 Tensile Requirements	5
5 Elongation Table	5
6 Impact Energy Requirements	7
7 Upset Drill Pipe for Weld-on Tool Joints Dimensions and Weights (Group 1)	11
8 Upset Drill Pipe for Weld-on Tool Joints Dimensions and Weights (Group 3)	13
9 Tolerances on Dimensions and Weights	14
10 Drill Pipe Upset Maximum Permissible Depth of Imperfections	15
11 Pipe Body Inspection Methods	16
12 Artificial Reference Indicators	17
A-1 Upset Drill Pipe for Weld-on Tool Joints—Dimensions and Weights (Group 1), Metric	21
A-2 Upset Drill Pipe for Weld-on Tool Joints—Dimensions and Weights (Group 3), Metric	22
A-3 Tolerances on Dimensions and Weights, Metric	23
SR20 Impact Energy Requirements	27

Specification for Drill Pipe

1 Scope

1.1 COVERAGE

1.1.1 This specification covers Group 1 and Group 3 drill pipe as described below in the designations and wall thicknesses as shown in the standards list, Table 1, and in the dimensional tables (Table 7 and Table 8). The requirements of this specification apply to both Groups unless specifically noted.

Group 1—Grade E drill pipe.

Group 3—All high strength grades of drill pipe.
(Grades X-95, G-105, and S-135)

1.1.2 In the dimensional tables herein, pipe is designated by outside diameter size. The outside diameter size of external-upset pipe is the outside diameter of the body of the drill pipe, not the upset portion.

1.2 RETENTION OF RECORDS

Tests and inspections requiring retention of records in this specification are shown in Table 2. Such records shall be retained by the manufacturer and shall be available to the purchaser on request for a 3-year period after the date of purchase from the manufacturer.

Table 1—API Drill Pipe List^a

Size	Weight Designation	Calculated Plain-End Weight		Outside Diameter		Wall Thickness		Grade	Upset Ends, for Weld-on Tool Joints
		lb/ft	kg/m	in.	mm	in.	mm		
		W_{pe}		D		t			
2 ³ / ₈	6.65	6.26	9.32	2.375	60.3	0.280	7.11	E, X, G, S	Ext. Upset
2 ⁷ / ₈	10.40	9.72	14.48	2.875	73.0	0.362	9.19	E, X, G, S	Int. Upset or Ext. Upset
3 ¹ / ₂	9.50	8.81	13.12	3.500	88.9	0.254	6.45	E	Int. Upset or Ext. Upset
3 ¹ / ₂	13.30	12.31	18.34	3.500	88.9	0.368	9.35	E, X, G, S	Int. Upset or Ext. Upset
3 ¹ / ₂	15.50	14.63	21.79	3.500	88.9	0.449	11.40	E	Int. Upset or Ext. Upset
3 ¹ / ₂	15.50	14.63	21.79	3.500	88.9	0.449	11.40	X, G, S	Ext. Upset or Int.-Ext. Upset
4	14.00	12.93	19.26	4.000	101.6	0.330	8.38	E, X, G, S	Int. Upset or Ext. Upset
4 ¹ / ₂	13.75	12.24	18.23	4.500	114.3	0.271	6.88	E	Int. Upset or Ext. Upset
4 ¹ / ₂	16.60	14.98	22.31	4.500	114.3	0.337	8.56	E, X, G, S	Ext. Upset or Int.-Ext. Upset
4 ¹ / ₂	20.00	18.69	27.84	4.500	114.3	0.430	10.92	E, X, G, S	Ext. Upset or Int.-Ext. Upset
5	16.25	14.87	22.15	5.000	127.0	0.296	7.52	X, G, S	Int. Upset
5	19.50	17.93	26.71	5.000	127.0	0.362	9.19	E	Int.-Ext. Upset
5	19.50	17.93	26.71	5.000	127.0	0.362	9.19	X, G, S	Ext. Upset or Int.-Ext. Upset
5	25.60	24.03	35.79	5.000	127.0	0.500	12.70	E	Int.-Ext. Upset
5	25.60	24.03	35.79	5.000	127.0	0.500	12.70	X, G, S	Ext. Upset or Int.-Ext. Upset
5 ¹ / ₂	21.90	19.81	29.51	5.500	139.7	0.361	9.17	E, X, G, S	Int.-Ext. Upset
5 ¹ / ₂	24.70	22.54	33.57	5.500	139.7	0.415	10.54	E, X, G, S	Int.-Ext. Upset
6 ⁵ / ₈	25.20	22.19	33.05	6.625	168.3	0.330	8.38	E, X, G, S	Int.-Ext. Upset
6 ⁵ / ₈	27.72	24.21	36.06	6.625	168.3	0.362	9.19	E, X, G, S	Int.-Ext. Upset

^aDrill pipe with special end finish is available under this specification. See 9.1.

1.3 TESTING EQUIPMENT

If test equipment, whose calibration or verification is required under the provisions of the specification, is subjected to unusual or severe conditions such as would make its accuracy questionable, recalibration or reverification shall be performed before further use of the equipment.

1.4 SPECIAL PROCESSES

Special Processes are the final operations which are performed during pipe manufacturing that affect attribute compliance required in this document (except chemistry and dimensions). The applicable special processes are heat treatment, nondestructive testing, and, if applicable, cold finishing.

1.5 CERTIFICATION

1.5.1 The manufacturer shall, upon request by the purchaser, furnish to the purchaser a certificate of compliance stating that the material has been manufactured, sampled, tested, and inspected in accordance with this specification and has been found to meet the requirements

1.5.2 A Material Test Report, Certificate of Compliance, or similar document printed from or used in electronic form from an electronic data interchange (EDI) transmission shall be regarded as having the same validity as a counterpart printed in the certifier's facility. The content of the EDI transmitted document must meet the requirements of this specification and conform to any existing EDI agreement between the purchaser and the supplier.

1.5.3 Where additional information is required, including the results of mechanical testing, SR15 shall be specified in the purchaser order.

Table 2—Retention of Records

Requirement	Reference
Chemical Properties	
Heat Analysis	5.2
Product Analysis	5.3
Mechanical Properties	
Tensile Tests	6.1
Control Tests	7.1.5
Calibration	Various Sections

2 References

2.1 GENERAL

This specification includes by reference, either in total or in part, other API, industry, and government standards listed in Table 2.

2.2 REQUIREMENTS

Requirements of other standards included by reference in this specification are essential to the safety and interchangeability of the equipment produced.

2.3 EQUIVALENT STANDARDS

Other nationally or internationally recognized standards shall be submitted to and approved by API for inclusion in this specification prior to their use as equivalent standards.

2.4 REFERENCED STANDARDS

Unless otherwise specified, the most recent editions or revisions of the following standards, codes, and specifications shall, to the extent specified herein, form a part of this standard.

ASTM¹

- ASTM A370 *Mechanical Testing of Steel Products, Annex II, Steel Tubular Products*
- ASTM A751 *Method, Practices and Definitions for Chemical Analysis of Steel Products*
- ASTM E4 *Practices for Load Verification of Testing Machines*
- ASTM E23 *Methods for Notched Bar Impact Testing of Metallic Materials*
- ASTM E83 *Methods of Verification and Classification of Extensometers*
- ASTM E165 *Standard Practice for Liquid Penetrant Inspection Method*
- ASTM E213 *Standard Practice for Ultrasonic Examination of Metal Pipe and Tubing*
- ASTM E309 *Standard Practice for Eddy-Current Examination of Steel Tubular Products Using Magnetic Saturation*
- ASTM E570 *Standard Practice for Flux Leakage Examination of Ferromagnetic Steel Tubular Products*
- ASTM E709 *Standard Practice for Magnetic Particle Examination*

ASNT²

- Recommended Practice SNT-TC-1A* (1984 edition)

¹American Society for Testing and Materials, 100 Barr Harbor Drive, West Conshohocken, Pennsylvania 19428-2959.

²American Society for Nondestructive Testing, 1711 Arlington Lane, P.O. Box 28518, Columbus, Ohio 43228-0318.

3 Definitions

For the purposes of this specification, the following definitions apply:

3.1 carload: The quantity of pipe loaded on a rail car for shipment from the pipe-making facilities.

3.2 defect: An imperfection of sufficient magnitude to warrant rejection of the product based on the stipulations of this specification.

3.3 elephant hide: The wrinkled outside diameter surfaces of the pipe caused by the upsetting of end areas exposed to forging temperatures.

3.4 heat: The metal produced by a single cycle of a batch melting process.

3.5 heat analysis: The chemical analysis representative of a heat as reported by the metal producer.

3.6 imperfection: A discontinuity or irregularity in the product detected by methods outlined in this specification.

3.7 inspection: The process of measuring, examining, testing, gauging, or otherwise comparing the unit of product with the applicable requirements.

3.8 inspection lot: A definite quantity of product manufactured under conditions that are considered uniform for the attribute to be inspected.

3.9 inspection lot sample: One or more units of product selected from an inspection lot to represent that inspection lot.

3.10 inspection lot size: The number of units in an inspection lot.

3.11 linear imperfections: Include, but are not limited to, cracks, seams, laps, plug scores, cuts, gouges, and elephant hide.

3.12 manufacturer: The term manufacturer as used throughout this specification refers to the firm, company, or corporation responsible for marking the product to warrant that the product conforms to the specification. The manufacturer may be either a pipe mill or processor. The manufacturer is responsible for compliance with all of the applicable provisions of the specification.

3.13 may: Used to indicate that a provision is optional.

3.14 nonlinear imperfections: Include, but are not limited to, pits and round bottom die-stamping.

3.15 outside diameter exposed surfaces: 1) For EUE and IEUE, the areas are the upset (L_{eu}), taper (m_{eu}), and adjacent pipe body. 2) For IUE, the area over the upset (L_{iu}), the area over the internal taper (m_{iu}), and the adjacent pipe body.

3.16 pipe mill: A firm, company, or corporation that operates pipe-making facilities.

3.17 processor: A firm, company, or corporation that operates facilities capable of heat treating pipe made by a pipe mill.

3.18 shall: Used to indicate that a provision is mandatory.

3.19 should: Used to indicate that a provision is not mandatory, but recommended as good practice.

4 Process of Manufacture

4.1 GENERAL

Drill pipe furnished to this specification shall be made by the seamless process defined as follows:

a. Seamless pipe is a wrought steel tubular product made without a welded seam. It is manufactured by hot-working steel, or if necessary, by subsequently cold-finishing the hot-worked tubular product to produce the desired shape, dimensions, and properties.

b. Cold drawn drill pipe, without appropriate heat treatment, is not acceptable.

4.2 HEAT TREATMENT

The heat treating process shall be performed in accordance with a documented procedure.

a. Group 1—Drill pipe shall be normalized or at the manufacturer's option normalized and tempered, or quenched and tempered full length; and if upset, shall be so heat treated after upsetting.

b. Group 3—Unless otherwise agreed upon between purchaser and manufacturer, drill pipe furnished to this specification shall be quenched and tempered, or normalized and tempered. Upset drill pipe shall be heat treated full length after upsetting.

4.3 PIPE MATERIAL

The various grades and groups of steel furnished to this specification shall be made to a fine grain practice. Steel made to fine grain practice contains one or more grain refining elements, such as aluminum, columbium, vanadium, or titanium in amounts intended to result in the steel having a fine austenitic grain size.

4.4 LOT DEFINITION—GROUPS 1 AND 3

A lot is defined as all those lengths of pipe with the same specified dimension and grade which are heat treated as part of the continuous operation (or batch) and are from a single heat of steel; or, from different heats that are grouped according to a documented procedure that will ensure the appropriate requirements of this specification are met.

4.5 TRACEABILITY

The manufacturer shall establish and follow procedures for maintaining heat and/or lot identity until all required heat and/or lot tests are performed and conformance with specification requirements has been shown.

5 Chemical Composition

5.1 CHEMICAL REQUIREMENTS

Drill pipe furnished to this specification shall conform to the chemical requirements specified in Table 3.

Table 3—Chemical Requirements

Steel	Phosphorus Max. Percent	Sulfur Max. Percent
All Groups	0.030	0.030

5.2 HEAT ANALYSES

When requested by the purchaser, the manufacturer shall furnish a report giving the heat analysis of each heat of steel used in the manufacture of pipe furnished on the purchase order. In addition, upon request the purchaser shall be furnished the results of quantitative analyses of other elements, in addition to phosphorus and sulfur, normally used by the manufacturer to control mechanical properties.

5.3 PRODUCT ANALYSES

Product analyses of each heat used shall be made on pipe. The results of the product analyses shall be available to the purchaser on request. Product analyses shall include the results of quantitative determinations of phosphorus and sulfur and, in addition, all other elements normally used by the manufacturer to control mechanical properties. Two samples shall be analyzed for product analyses.

5.4 RECHECK PRODUCT ANALYSES—ALL GROUPS

If the product analyses of both lengths of pipe representing the heat fail to conform to the specified requirements, at the manufacturer's option, either the heat shall stand rejected or all the remaining lengths in the heat shall be tested individually for conformance to the specified requirements. If only one of two samples fails, at the manufacturer's option either the heat shall stand rejected or two recheck analyses shall be made on two additional lengths from the same heat. If both recheck analyses conform to the requirements, the heat shall be accepted, except for the length represented by the initial analyses, which failed. If one or both of the recheck analyses fail, at the manufacturer's

option the entire heat shall be rejected, or each of the remaining lengths shall be tested individually. In the individual testing of the remaining lengths in any heat, analyses for only the rejecting element or elements need be determined. Samples for recheck product analyses shall be taken in the same manner as specified for product analysis samples. The results of all recheck product analyses shall be provided to the purchaser when specified on the purchase order.

6 Mechanical Properties Requirements

6.1 TENSILE PROPERTIES

6.1.1 Pipe furnished to this specification shall conform to the tensile requirements specified in Table 4 for the particular grade ordered. When elongation is recorded or reported, the record or report shall show the nominal width of the test specimen when strip specimens are used; the diameter and gauge length when round bar specimens are used; or state when full section specimens are used. The tensile properties, except elongation, of the upset ends shall comply with the requirements given for the pipe body. In case of dispute, the properties (except elongation) of the upset shall be determined from a tensile test specimen cut from the upset.

6.1.2 See the equation in Table 4 for determination of the minimum elongation and Table 5 for minimum elongation values for various size tensile specimens and grades.

6.2 YIELD STRENGTH

The yield strength shall be the tensile stress required to produce a total elongation of the gauge length, as determined by an extensometer, as follows:

Grade	Total Extension of Gauge Length, Percent
E-75	0.5
X-95	0.5
G-105	0.6
S-135	0.7

6.3 LONGITUDINAL IMPACT REQUIREMENTS

6.3.1 Group 1 (Grade E)

By agreement between the purchaser and the manufacturer, pipe furnished to this specification shall conform to the requirements specified in SR19.

6.3.2 Group 3 (Grades X, G, and S)

Material shall conform to the requirements specified in 6.4.

Table 4—Tensile Requirements

1	2	3		4		5		6	
		Yield Strength				Tensile Strength Min.			Elongation, Min. Percent in 2 in. (50.80 mm)
		Minimum		Maximum		psi	MPa		
Group	Grade	psi	MPa	psi	MPa			psi	MPa
1	E-75	75,000	517	105,000	724	100,000	689	See footnote ^a	
3	X-95	95,000	655	125,000	862	105,000	724	See footnote ^a	
	G-105	105,000	724	135,000	931	115,000	793	See footnote ^a	
	S-135	135,000	931	165,000	1138	145,000	1000	See footnote ^a	

^aThe minimum elongation in 2 in. (50.80 mm) shall be that determined by the following formula:

$$e = 625,000 \frac{A^{0.2}}{U^{0.9}}$$

where

e = minimum elongation in 2 in. (50.80 mm) in percent rounded to nearest 0.5%,

A = cross-sectional area of the tensile test specimen in square inches, based on specified outside diameter, or nominal specimen width, and specified wall thickness, rounded to the nearest 0.01 in.², or 0.75 in.², whichever is smaller,

U = specified tensile strength, psi.

Note: See Table 5 for minimum elongation values for various size strip tensile specimens and grades. The minimum elongation for either round bar tensile specimen (0.350-in. diameter with 1.4-in. gauge length and the 0.500-in. diameter with 2.00-in. gauge length) shall be that shown in Table 5 for a cross-sectional area “A” of 0.20 in.².

Table 5—Elongation Table

Tabulated below are the minimum elongation values calculated by the formula given in Table 4.

1	2	3	4	5				7	8
				Elongation in 2 in., Minimum, Percent					
				Tensile Test Specimen			Grade		
Area A in. ²	Specified Wall Thickness, in.			E-75	X-95	G-105	S-135		
	3/4 in. Strip Specimen	1 in. Strip Specimen	1 1/2 in. Strip Specimen	Specified Tensile Strength, psi					
				100,000	105,000	115,000	145,000		
0.75 and Greater	.994 and Greater	.746 and Greater	.497 and Greater	18.5	18.0	16.5	13.5		
0.74	.980–.993	.735–.745	.490–.496	18.5	18.0	16.5	13.5		
0.73	.967–.979	.726–.734	.484–.489	18.5	18.0	16.5	13.5		
0.72	.954–.966	.715–.725	.477–.483	18.5	17.5	16.5	13.0		
0.71	.941–.953	.706–.714	.471–.476	18.5	17.5	16.5	13.0		
0.70	.927–.940	.695–.705	.464–.470	18.5	17.5	16.0	13.0		
0.69	.914–.926	.686–.694	.457–.463	18.5	17.5	16.0	13.0		
0.68	.900–.913	.675–.685	.450–.456	18.5	17.5	16.0	13.0		
0.67	.887–.899	.666–.674	.444–.449	18.0	17.5	16.0	13.0		
0.66	.874–.886	.655–.665	.437–.443	18.0	17.5	16.0	13.0		
0.65	.861–.873	.646–.654	.431–.436	18.0	17.5	16.0	13.0		
0.64	.847–.860	.635–.645	.424–.430	18.0	17.5	16.0	13.0		
0.63	.834–.846	.626–.634	.417–.423	18.0	17.0	16.0	13.0		
0.62	.820–.833	.615–.625	.410–.416	18.0	17.0	16.0	13.0		
0.61	.807–.819	.606–.614	.404–.409	18.0	17.0	16.0	13.0		
0.60	.794–.806	.595–.605	.397–.403	18.0	17.0	15.5	13.0		
0.59	.781–.793	.586–.594	.391–.396	18.0	17.0	15.5	12.5		
0.58	.767–.780	.575–.585	.384–.390	17.5	17.0	15.5	12.5		
0.57	.754–.766	.566–.574	.377–.383	17.5	17.0	15.5	12.5		
0.56	.740–.753	.555–.565	.370–.376	17.5	17.0	15.5	12.5		
0.55	.727–.739	.546–.554	.364–.369	17.5	17.0	15.5	12.5		

Table 5—Elongation Table (Continued)

Tabulated below are the minimum elongation values calculated by the formula given in Table 4.

1	2	3	4	5	6				7	8			
					Elongation in 2 in., Minimum, Percent								
					Tensile Test Specimen			Grade					
					Specified Wall Thickness, in.			E-75			X-95	G-105	S-135
Area A in. ²	³ / ₄ in. Strip Specimen	1 in. Strip Specimen	1 ¹ / ₂ in. Strip Specimen	Specified Tensile Strength, psi									
				100,000	105,000	115,000	145,000						
0.54	.714-.726	.535-.545	.357-.363	17.5	16.5	15.5	12.5						
0.53	.701-.713	.526-.534	.351-.356	17.5	16.5	15.5	12.5						
0.52	.687-.700	.515-.525	.344-.350	17.5	16.5	15.5	12.5						
0.51	.674-.686	.506-.514	.337-.343	17.5	16.5	15.0	12.5						
0.50	.660-.673	.495-.505	.330-.336	17.0	16.5	15.0	12.5						
0.49	.647-.659	.486-.494	.324-.329	17.0	16.5	15.0	12.5						
0.48	.634-.646	.475-.485	.317-.323	17.0	16.5	15.0	12.0						
0.47	.621-.633	.466-.474	.311-.316	17.0	16.5	15.0	12.0						
0.46	.607-.620	.455-.465	.304-.310	17.0	16.0	15.0	12.0						
0.45	.594-.606	.446-.454	.297-.303	17.0	16.0	15.0	12.0						
0.44	.580-.593	.435-.445	.290-.296	17.0	16.0	15.0	12.0						
0.43	.567-.579	.426-.434	.284-.289	16.5	16.0	14.5	12.0						
0.42	.554-.566	.415-.425	.277-.283	16.5	16.0	14.5	12.0						
0.41	.541-.553	.406-.414	.271-.276	16.5	16.0	14.5	12.0						
0.40	.527-.540	.395-.405	.264-.270	16.5	15.5	14.5	12.0						
0.39	.514-.526	.386-.394	.257-.263	16.5	15.5	14.5	11.5						
0.38	.500-.513	.375-.385	.250-.256	16.5	15.5	14.5	11.5						
0.37	.487-.499	.366-.374	.244-.249	16.0	15.5	14.5	11.5						
0.36	.474-.486	.355-.365	.237-.243	16.0	15.5	14.0	11.5						
0.35	.461-.473	.346-.354	.231-.236	16.0	15.5	14.0	11.5						
0.34	.447-.460	.335-.345	.224-.230	16.0	15.0	14.0	11.5						
0.33	.434-.446	.326-.334	.217-.223	16.0	15.0	14.0	11.5						
0.32	.420-.433	.315-.325	.210-.216	15.5	15.0	14.0	11.5						
0.31	.407-.419	.306-.314	.204-.209	15.5	15.0	14.0	11.0						
0.30	.394-.406	.295-.305	.197-.203	15.5	15.0	13.5	11.0						
0.29	.381-.393	.286-.294	.191-.196	15.5	15.0	13.5	11.0						
0.28	.367-.380	.275-.285	.184-.190	15.5	14.5	13.5	11.0						
0.27	.354-.366	.266-.274	.177-.183	15.0	14.5	13.5	11.0						
0.26	.340-.353	.255-.265	.170-.176	15.0	14.5	13.5	11.0						
0.25	.327-.339	.246-.254	.164-.169	15.0	14.5	13.0	10.5						
0.24	.314-.326	.235-.245	.157-.163	15.0	14.0	13.0	10.5						
0.23	.301-.313	.223-.234	.151-.156	14.5	14.0	13.0	10.5						
0.22	.287-.300	.215-.225	.144-.150	14.5	14.0	13.0	10.5						
0.21	.274-.286	.206-.214	.137-.143	14.5	14.0	13.0	10.5						
0.20	.260-.273	.195-.205	.130-.136	14.5	13.5	12.5	10.5						
0.19	.247-.259	.186-.194	.124-.129	14.0	13.5	12.5	10.0						
0.18	.234-.246	.175-.185	.117-.123	14.0	13.5	12.5	10.0						
0.17	.221-.233	.166-.174	.111-.116	14.0	13.5	12.0	10.0						
0.16	.207-.220	.155-.165	.104-.110	13.5	13.0	12.0	10.0						
0.15	.194-.206	.146-.154	.097-.103	13.5	13.0	12.0	9.5						
0.14	.180-.193	.135-.145	.091-.096	13.5	13.0	12.0	9.5						

6.4 ENERGY REQUIREMENTS, LONGITUDINAL CHARPY IMPACT TESTS

Standard specimens 10 x 10 mm in cross section shall be used unless the wall thickness of the pipe to be tested is of insufficient thickness, in which case the largest obtainable subsize specimen shall be used. The minimum impact energy requirements for longitudinal specimens tested at 70°F ± 5°F (21°C ± 2.8°C) shall be as listed in Table 6.

6.5 ALTERNATE LOW TEMPERATURE ENERGY REQUIREMENTS

By agreement between the purchaser and the manufacturer, pipe furnished to this specification shall conform to the requirements specified in SR20.

7 Testing

7.1 TENSILE TESTS

7.1.1 Procedures

Tensile properties of the pipe body shall be determined by tests on longitudinal specimens conforming to the requirements of 7.1.3, and the latest edition of ASTM A370. Tensile tests shall be made with the specimens at room temperature. The strain rate during tensile testing shall be in accordance with the requirements of the latest edition of ASTM A370.

7.1.2 Equipment

Tensile test machines shall have been calibrated within 15 months preceding any test in accordance with the procedures of ASTM E4. Extensometers shall be calibrated within 15 months preceding any test in accordance with the procedures of ASTM E83. Records retention shall be per 1.3.

7.1.3 Specimens

Tensile test specimens from the pipe body shall be either full-section specimens, strip specimens, or round bar specimens as shown in Figure 1, at the option of the manufacturer. The type and size of the specimen shall be reported. Round bar specimens shall be taken from the mid-wall. Strip specimens and round bar specimens may be taken from any location about the pipe circumference at the option of the manufacturer. Tensile test specimens shall be removed from pipe subsequent to final heat treatment on the production line. All strip specimens shall be approximately 1½ in. (38.1 mm) wide in the gauge length if suitable curved face testing grips are used, or if the ends of the specimen are machined or cold flattened to reduce the curvature in the grip area; otherwise they shall be approximately ¾ in. (19.0 mm) wide for pipe 3½ in. and smaller and approximately 1 in. (25.4 mm) wide for pipe 4 in. and larger. All specimens shall represent the full wall thickness of the pipe from which the specimen was cut, except for round

Table 6—Impact Energy Requirements

1	2	3
Specimen Size mm x mm	Minimum Average Charpy V-notch Impact Energy of Each Set of Three Specimens ft/lb (J)	Minimum Charpy V-notch Impact Energy of Any Specimen of a Set ft/lb (J)
10 x 10.0	40 (54)	35 (47)
10 x 7.5	32 (43)	28 (38)
10 x 5.0	22 (30)	19 (26)

bar tensile specimens, and shall be tested without flattening. The 0.500 in. (12.7 mm) diameter round bar specimen shall be used when the pipe size allows, and the 0.350 in. (8.75 mm) diameter round bar specimen shall be used for other sizes. For pipe sizes too small to allow a 0.350 in. (8.75 mm) specimen, round bar tensile specimens are not permitted.

7.1.4 Number of Tensile Tests

7.1.4.1 Group 1 (Grade E)

One tensile test shall be made on a length of drill pipe from each lot of 400 lengths or less of each size 5½ in. and smaller, and from each lot of 200 lengths or less of each size 6⅝ in. and larger, provided that, in the case of heat treated pipe, all the lengths in each lot shall have received the same heat treatment. For multiple-length seamless pipe, a length shall be considered as all of the sections cut from a particular multiple length.

7.1.4.2 Group 3 (Grades X, G, and S)

One tensile test shall be made on a length of drill pipe from each lot of 200 lengths or less of each size 5½ in. and smaller; and from each lot of 100 lengths or less of each size 6⅝ in. and larger; provided that, in the case of heat treated pipe, all the lengths in each lot shall have received the same heat treatment. For multiple-length seamless pipe, a length shall be considered as all of the sections cut from a particular multiple length.

7.1.5 Mill Control Tests

One tensile test shall be made as a control on each heat of steel used by the manufacturer for the production of pipe under this specification. A record of such tests shall be available to the purchaser.

7.1.6 Retests

If the tensile test specimen representing a lot of pipe fails to conform to the specified requirements, the manufacturer may elect to make retests on three additional lengths from the same

lot. If all of the retest specimens conform to the requirements, all the lengths in the lot shall be accepted except the length from which the initial specimen was taken. If more than one of the original test specimens fails or one or more of the retest specimens fail to conform to the specified requirements, the manufacturer may elect to individually test the remaining lengths in the lot, in which case determinations are necessary only for the particular requirements with which the specimens failed to comply in the preceding tests. Specimens for retests shall be taken in the same manner as specified in 7.1.3. Material from the same heat of steel which has been rejected by one or more of the above criteria may be reheat treated and retested, as by definition it is then a new lot of pipe.

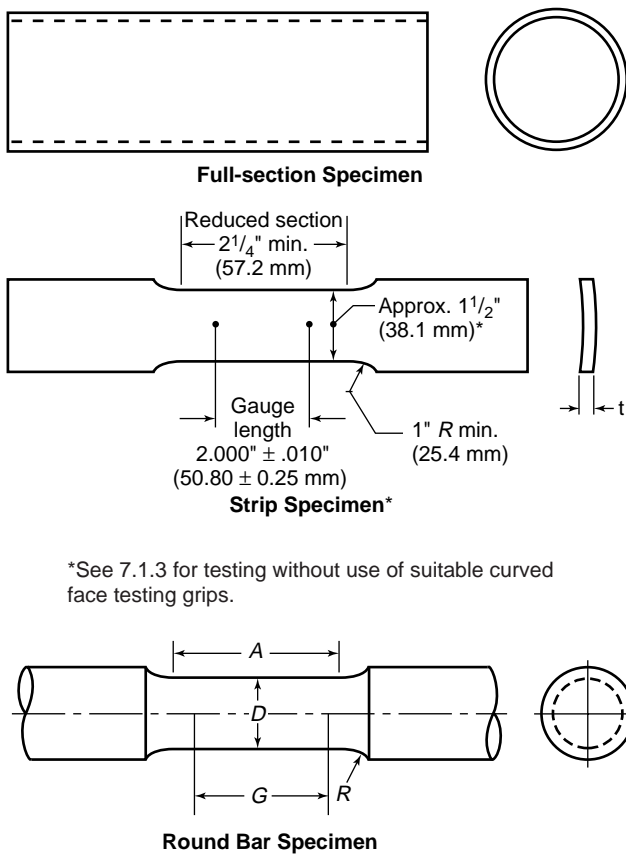

*See 7.1.3 for testing without use of suitable curved face testing grips.

Round Bar Specimen

	0.500 in. Diameter		0.350 in. Diameter	
	in.	mm	in.	mm
G Gauge length	2.000 ± 0.005	50.0 ± 0.10	1.400 ± 0.005	35.0 ± 0.10
D Diameter	0.500 ± 0.010	12.5 ± 0.25	0.350 ± 0.007	8.75 ± 0.18
R Radius of fillet, min.	$\frac{3}{8}$	10	$\frac{1}{4}$	6
A Length of reduced section, min.	$2\frac{1}{4}$	60	$1\frac{3}{4}$	45

Figure 1—Tensile Test Specimens

7.1.7 Defective Specimens

If any tensile specimen shows defective machining or develops flaws, it may be discarded and another specimen substituted. When the elongation of any tensile specimen is less than that specified, if any part of the fracture is outside the middle third of the gauge length, as indicated by scribe scratches marked on the specimen before testing, a retest shall be allowed.

7.2 CHEMICAL ANALYSIS

Chemical analyses shall be determined by any of the procedures commonly used for determining chemical compositions such as emission spectroscopy, X-ray emission, atomic absorption, combustion techniques or wet analytical procedures. The calibration methods used shall be traceable to established standards. All chemical analyses shall be made in accordance with ASTM A751.

7.3 LONGITUDINAL IMPACT TESTS

7.3.1 Procedures

Charpy V-notch Type A impact tests shall be conducted at $70^{\circ}\text{F} \pm 5^{\circ}\text{F}$ ($21^{\circ}\text{C} \pm 2.8^{\circ}\text{C}$). Tests shall be conducted as specified in the latest edition of ASTM A370 and ASTM E23. For alternate test temperature, see SR20. A test shall consist of three specimens. The energy requirements are specified in 6.3.

7.3.2 Impact Specimens

Three specimens shall be taken parallel to the axis of the pipe with the notch oriented radially as shown in Figure 2. Impact test specimens shall not be machined from pipe which has been flattened.

7.3.3 Defective Specimens

Specimens showing material imperfections or defective preparation, whether observed before or after breaking, may be discarded, and replacements shall be considered as original specimens. Specimens shall not be judged defective simply because they failed to exhibit the minimum absorbed energy requirement.

7.3.4 Frequency of Testing—Group 3 (Grades X, G, and S)

Three Charpy V-notch specimens representing one test shall be taken from one length of drill pipe from each lot of 200 lengths or less of sizes $5\frac{1}{2}$ and smaller, and from each lot of 100 lengths or less of size $6\frac{5}{8}$, provided that, in the case of heat-treated pipe, all lengths have received the same heat treatment. For multiple-length seamless pipe, a length shall be considered as all of the sections cut from a particular multiple length.

7.3.5 Impact Retest—All Groups

7.3.5.1 If the impact test of a set of specimens does not meet the requirements of 6.3, the manufacturer may retest a set of three additional specimens from the same length of pipe. All three of these specimens shall have energy values equal to or exceeding the minimum average values in Table 6.

7.3.5.2 If the retested specimens fail to conform to the requirement in 7.3.5.1, an additional set of three specimens shall be taken from each of two additional lengths from the same lot. If these retested specimens from both lengths conform to the requirements in Table 6 then the lot shall be qualified except for the length initially rejected. At the option of the manufacturer, the lot may be reheat treated and retested.

7.4 DIMENSIONAL AND WEIGHT TESTS

7.4.1 Weight Tests

Each length of drill pipe shall be weighed separately. The pipe manufacturer or the pipe processor shall be responsible for weighing the pipe to determine compliance with weight tolerance. The pipe may be weighed plain-end, upset or non-upset. For drill pipe with integral rotary connections or attached rotary connections, allowance shall be made for the effective connection weight.

7.4.2 Wall Thickness

The wall thickness at any place shall not be less than the tabulated thickness minus the permissible undertolerance specified in Table 9. Wall-thickness measurements shall be made with a mechanical caliper or with a properly calibrated nondestructive testing device of appropriate accu-

racy. In case of dispute, the measurement determined by use of the mechanical caliper shall govern. The mechanical caliper shall be fitted with contact pins having circular cross sections of $1/4$ in. (6.35 mm) diameter. The end of the pin contacting the inside surface of the pipe shall be rounded to a maximum radius of $d/4$ with a minimum radius of $1/8$ in. The end of the pin contacting the outside surface of the pipe shall be either flat or rounded to a radius of not less than $1\frac{1}{2}$ in. (38.10 mm).

7.4.3 Drift Test

All drift testing shall be performed with a drift mandrel containing a cylindrical portion conforming to the requirements shown in 8.7. The ends of the drift mandrel extending beyond the specified cylindrical portion shall be shaped to permit easy entry into the pipe. The drift mandrel shall pass freely through the pipe by the use of a manual or power drift procedure. In case of dispute, the manual drift procedure shall be used. Drill pipe shall not be rejected until it has been drift tested when it is free of all foreign matter and properly supported to prevent sagging.

7.4.4 Length Measurement

The length shall be measured from end to end, including the upsets, but not including the tool joints.

7.4.5 Straightness

Pipe sizes $4\frac{1}{2}$ and larger shall be checked for straightness when necessary by using a straight edge or taut string (wire). Deviation from straight, or chord height, shall not exceed the requirements in 8.6.

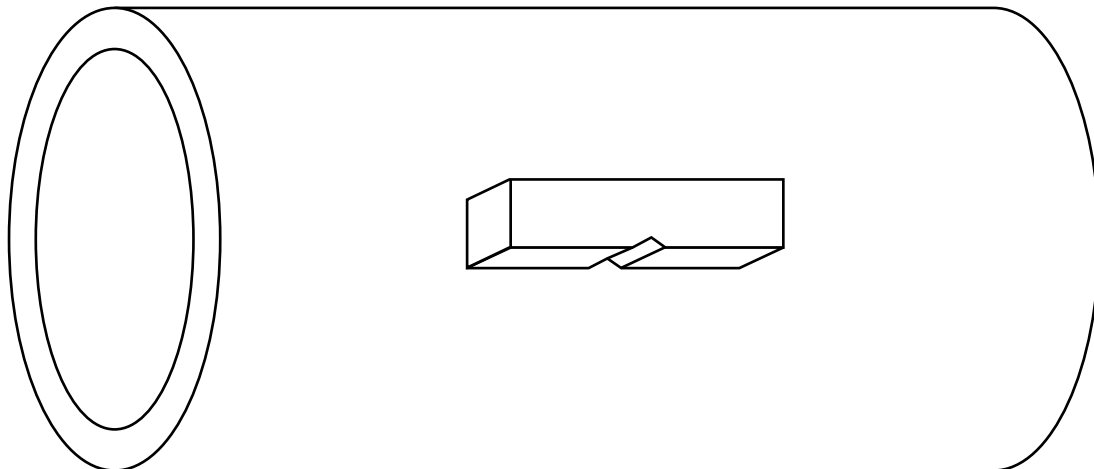

Figure 2—Impact Test Specimen Orientation—Longitudinal Specimens

8 Requirements for Dimensions, Weights, Lengths, and Defects

8.1 DIMENSIONS AND WEIGHTS

8.1.1 Pipe shall be furnished in the sizes, wall thicknesses, and weights (as shown in Tables 7 and 8) as specified on the purchase order. All dimensions shown without tolerance are related to the basis for design and are not subject to measurement to determine acceptance or rejection of product.

8.1.2 The accuracy of all measuring instruments used for acceptance/rejection shall be verified at least once every operating shift. Accuracy verification of rules, length measuring tapes, and other nonadjustable measuring devices shall be defined as a visual check of markings' legibility and the general wear of fixed reference points. The verification procedure of these working gages shall be documented. The adjustable and nonadjustable designation used by the manufacturer shall be documented.

8.1.3 If measuring equipment, whose calibration or verification is required under the provisions of the specification, is subjected to unusual or severe conditions such as would make its accuracy questionable, recalibration or reverification shall be performed prior to further use of the equipment.

8.2 DIAMETER

The outside diameter shall be within the tolerances specified in Table 9. (Inside diameters are governed by the outside diameter and weight tolerances.)

8.3 WALL THICKNESS

Each length of pipe shall be measured for compliance with wall-thickness requirements. The wall thickness at any place shall not be less than the tabulated thickness minus the permissible undertolerance specified in Table 9.

8.4 WEIGHT

Each length of drill pipe shall be weighed separately. The weights determined as described in 7.4 shall conform to the specified calculated weights (or adjusted calculated weights) for the end finish specified on the purchase order, within the tolerances stipulated in Table 9. Calculated weights shall be determined in accordance with the following formula:

$$W_L = (w_{pe} \times L) + e_w$$

where

W_L = calculated weight of a piece of pipe of length L , lb (kg),

w_{pe} = plain-end weight, lb/ft (kg/m),

L = length of pipe, including end finish, as defined in 8.5, ft (m),

e_w = weight gain or loss due to end finishing, lb (kg).
For plain-end (nonupset) pipe, e_w equals zero.

8.5 LENGTH

Pipe shall be furnished in range lengths conforming to Table 9 as specified on the purchase order. Length determination shall be in feet and tenths of a foot. The accuracy of length measuring devices for lengths of pipe less than 100 ft (30 m) shall be ± 0.1 ft (0.03 m).

8.6 STRAIGHTNESS

All drill pipe $4\frac{1}{2}$ inches and larger shall be measured for straightness as described in 7.4.5. Deviation from straight or chord height shall not exceed either of the following:

- 0.2% of the total length of the pipe measured from one end of the pipe to the other end.
- 0.125 in. of the 5 ft length at each end.

Measurement of the deviation shall not be made in the plane of the upset or the upset fade-away.

8.7 DRIFT REQUIREMENTS

Each length of Group 1 external upset drill pipe, except $3\frac{1}{2}$ in. 13.30 lb, shall be tested throughout the length of the end upset with a drift mandrel having a diameter, $d - \frac{3}{16}$ in. ($d - 4.76$ mm) smaller than the tabulated d of the drill pipe, and a length of 4 in. (102 mm).

8.8 IMPERFECTIONS AND DEFECTS

An imperfection is a discontinuity or irregularity in the product, detected by methods outlined in this specification. An imperfection is considered a defect when it is of sufficient magnitude to warrant rejection of the product based on the stipulations of this specification. All pipe shall be free from defects as defined below:

8.8.1 Surface Breaking Pipe Body Defects

Any imperfection on the outside or inside surface, of any orientation, shall be considered a defect if:

- It is linear and deeper than 12.5% of the specified wall thickness in the radial direction for Grades E-75, X-95, G-105, or is linear and deeper than 5% of the specified wall thickness in the radial direction for Grades S-135; or,
- It is linear or nonlinear and results in a wall thickness above or below the imperfection with a value less than 87.5% of the specified wall thickness.

Note: Linear imperfections include, but are not limited to, cracks, seams, laps, plug scores, cuts, gouges, and elephant hide. Nonlinear

Table 7—Upset Drill Pipe for Weld-on Tool Joints
Dimensions and Weights (Group 1)

1		2	3	4	5		6	7	8	9	10	11	12	13
Designations ^a		Outside Diameter	Wall Thickness	Inside Diameter	Plain End	Upset ^d	Outside Diameter ²	Inside Diameter at End of Pipe, ^c	Upset ^g	Length of Internal Taper, ^g	Length of External Upset,	Length of External Taper		Length End of Pipe to Taper Fadeout, Max.
Size	Weight	<i>D</i>	<i>t</i>	<i>d</i>	<i>w_{pe}</i>	<i>e_w</i>	<i>D_{ou}</i>	<i>d_{ou}</i>	<i>L_{iu}</i>	<i>m_{iu}</i>	<i>L_{eu}</i>	<i>m_{eu}</i>		<i>L_{eu} + m_{eu}</i>
Internal-Upset Drill Pipe														
2 ⁷ / ₈	10.40	2.875	0.362	2.151	9.72	3.20	2.875	1 ⁵ / ₁₆	1 ³ / ₄	1 ¹ / ₂	—	—	—	—
3 ¹ / ₂	9.50	3.500	0.254	2.992	8.81	4.40	3.500	2 ¹ / ₄	1 ³ / ₄	—	—	—	—	—
3 ¹ / ₂	13.30	3.500	0.368	2.764	12.31	4.40	3.500	1 ¹⁵ / ₁₆	1 ³ / ₄	1 ¹ / ₂	—	—	—	—
3 ¹ / ₂	15.50	3.500	0.449	2.602	14.63	3.40	3.500	1 ¹⁵ / ₁₆	1 ³ / ₄	1 ¹ / ₂	—	—	—	—
*4	11.85	4.000	0.262	3.476	10.46	4.20	4.000	2 ¹⁵ / ₁₆	1 ³ / ₄	—	—	—	—	—
4	14.00	4.000	0.330	3.340	12.93	4.60	4.250	2 ³ / ₄	1 ³ / ₄	2	—	—	—	—
*4 ¹ / ₂	13.75	4.500	0.271	3.958	12.24	5.20	4.750	3 ³ / ₈	1 ³ / ₄	—	—	—	—	—
*5	16.25	5.000	0.296	4.408	14.87	6.60	5.000	3 ³ / ₄	1 ³ / ₄	—	—	—	—	—
External-Upset Drill Pipe														
2 ³ / ₈	6.65	2.375	0.280	1.815	6.26	1.80	2.656	1.815	—	—	1 ¹ / ₂	1 ¹ / ₂	—	4
2 ⁷ / ₈	10.40	2.875	0.362	2.151	9.72	2.40	3.219	2.151	—	—	1 ¹ / ₂	1 ¹ / ₂	—	4
3 ¹ / ₂	9.50	3.500	0.254	2.992	8.81	2.60	3.938	2.992	—	—	1 ¹ / ₂	1 ¹ / ₂	—	4
3 ¹ / ₂	13.30	3.500	0.368	2.764	12.31	4.00	3.938	2.602	2 ¹ / ₄	2	1 ¹ / ₂	1 ¹ / ₂	—	4
3 ¹ / ₂	15.50	3.500	0.449	2.602	14.63	2.80	3.938	2.602	—	—	1 ¹ / ₂	1 ¹ / ₂	—	4
*4	11.85	4.000	0.262	3.476	10.46	5.00	4.500	3.476	—	—	1 ¹ / ₂	1 ¹ / ₂	—	4
4	14.00	4.000	0.330	3.340	12.93	5.00	4.563	3.340	—	—	1 ¹ / ₂	1 ¹ / ₂	—	4
*4 ¹ / ₂	13.75	4.500	0.271	3.958	12.24	5.60	5.063	3.958	—	—	1 ¹ / ₂	1 ¹ / ₂	—	4
4 ¹ / ₂	16.60	4.500	0.337	3.826	14.98	5.60	5.063	3.826	—	—	1 ¹ / ₂	1 ¹ / ₂	—	4
4 ¹ / ₂	20.00	4.500	0.430	3.640	18.69	5.60	5.063	3.640	—	—	1 ¹ / ₂	1 ¹ / ₂	—	4
Internal-External Upset Drill Pipe														
4 ¹ / ₂	16.60	4.500	0.337	3.826	14.98	8.10	4.750	3 ⁵ / ₃₂	2 ¹ / ₂	2	1 ¹ / ₂	1	1 ¹ / ₂	—
4 ¹ / ₂	20.00	4.500	0.430	3.640	18.69	8.60	4.781	3	2 ¹ / ₄	2	1 ¹ / ₂	1	1 ¹ / ₂	—
5	19.50	5.000	0.362	4.276	17.93	8.60	5.188	3 ¹¹ / ₁₆	2 ¹ / ₄	2	1 ¹ / ₂	1	1 ¹ / ₂	—
5	25.60	5.000	0.500	4.000	24.03	7.80	5.188	3 ⁷ / ₁₆	2 ¹ / ₄	2	1 ¹ / ₂	1	1 ¹ / ₂	—
5 ¹ / ₂	21.90	5.500	0.361	4.778	19.81	10.60	5.750	4	2 ¹ / ₄	2	1 ¹ / ₂	1	1 ¹ / ₂	—
5 ¹ / ₂	24.70	5.500	0.415	4.670	22.54	9.00	5.750	4	2 ¹ / ₄	2	1 ¹ / ₂	1	1 ¹ / ₂	—
6 ⁵ / ₈	25.20	6.625	0.330	5.965	22.19	25.87	7.000	5.315	4 ¹ / ₂	2	3	—	—	5 ¹ / ₂
6 ⁵ / ₈	27.70	6.625	0.362	5.901	24.21	24.00	7.000	5.315	4 ¹ / ₂	2	3	—	—	5 ¹ / ₂

^aDesignations (Column 1) are shown for the purpose of identification in ordering.

^bFor internal-upset drill pipe, the tolerance on the outside diameter of the upset, *D_{ou}*, shall be + 1/8, - 0 in. A slight external upset within these tolerances is permissible.

^cMaximum taper on inside diameter of internal upset and internal-external upset is 1/4 in./ft on diameter.

^dWeight gain or loss due to end finishing. See 8.4.

^eThe specified upset dimensions do not necessarily agree with the bore and OD dimensions of finished weld-on assemblies. Upset dimensions were chosen to accommodate the various bores of tool joints and to maintain a satisfactory cross section in the weld zone after final machining of the assembly.

^fBy agreement between purchaser and manufacturer or processor, the length of upset for Grade E drill pipe may be the same as for the higher grades in Group 3.

^g3¹/₂" OD 13.3 lb/ft External-Upset Drill Pipe has a slight internal upset not illustrated in Figure 3.

^h*L_{iu}* tolerance for 6⁵/₈ weights is + 2, - 1/2 in.

*These sizes and weights are tentative.

Notes:

1. See Figure 3.
2. See Appendix A for metric tables.

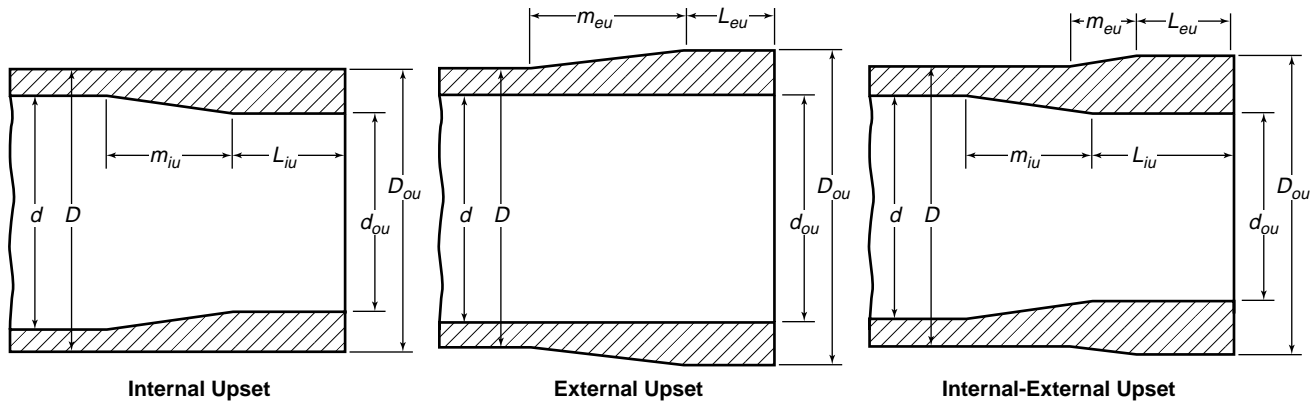

Note: See Table 7 for drill pipe dimensions.

Figure 3—Upset Drill Pipe for Weld-on Tool Joints (Group 1)

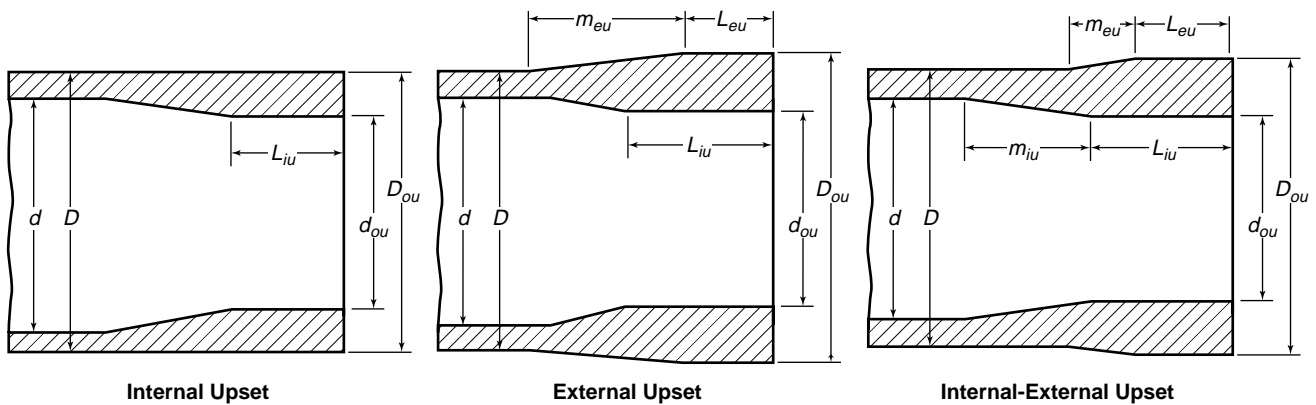

Notes:

- See Table 8 for drill pipe dimensions.
- Permissible internal taper within length L_{iu} shall not exceed $1/4$ in./ft (21 mm/m) on diameter.

Figure 4—Upset Drill Pipe for Weld-on Tool Joints (Group 3)

imperfections include, but are not limited to, pits and round bottom die-stamping.

8.8.2 Surface Breaking Pipe Upset Defects

Any imperfection on the outside or inside surface, of any orientation, that is deeper than shown in Table 10, shall be considered a defect. The internal upset configuration on all upset products shall exhibit no sharp corners or drastic changes of section that would cause a 90° hook-type tool to hang up.

8.8.3 Elephant hide

Elephant hide is the wrinkled outside diameter surfaces of the pipe caused by the upsetting of end areas exposed to forg-

ing temperatures. The outside diameter exposed surfaces are 1) for EUE and IEUE, the areas are the upset (L_{eu}), taper (m_{eu}), and adjacent pipe body; and 2) for IUE, the area over the upset (L_{iu}), the area over the internal taper (m_{iu}), and the adjacent pipe body.

8.8.4 Quench Cracks

Quench cracks detected by methods outlined in this specification shall be considered defects.

Note: Quench cracks in steel result from stresses produced during the austenite-to-martensite transformation, which is accompanied by an increase in volume (Reference: American Society for Metals, *Metals Handbook*, Volume 20).

Table 8—Upset Drill Pipe for Weld-on Tool Joints
Dimensions and Weights (Group 3)

1		2	3	4	5	6	7	8	9	10	11	12
Designations ^a		Outside Diameter	Wall Thickness in.	Inside Diameter in.	Calculated Weight		Upset Dimensions, in. ^{5,6}					
					Plain End lb/ft	Upset ^d lb	Outside Diameter ^b + ¹ / ₈ , - ¹ / ₃₂	Inside Diameter at End of Pipe, ^c ± ¹ / ₁₆	Length of Internal Upset + ¹ / ₂ ^f - ¹ / ₂	Length of Internal Taper, Min.	Length of External Upset, Min.	Length End of Pipe to Taper Fadeout, Ext. Upset Max.
Size	Weight	<i>D</i>	<i>t</i>	<i>d</i>	<i>w_{pe}</i>	<i>e_w</i>	<i>D_{ou}</i>	<i>d_{ou}</i>	<i>L_{iu}</i>	<i>m_{iu}</i>	<i>L_{eu}</i>	<i>L_{eu} + m_{eu}</i>
Internal-Upset Drill Pipe												
2 ⁷ / ₈	10.40	2.875	0.362	2.151	9.72	5.40	2.875	1 ⁵ / ₁₆	3 ¹ / ₂	—	—	—
3 ¹ / ₂	13.30	3.500	0.368	2.764	12.31	7.40	3.500	1 ¹⁵ / ₁₆	3 ¹ / ₂	—	—	—
4	14.00	4.000	0.330	3.340	12.93	8.80	4.250	2 ⁵ / ₈	3 ¹ / ₂	—	—	—
5	16.25	5.000	0.296	4.408	14.87	13.60	5.000	3 ⁹ / ₁₆	3 ¹ / ₂	—	—	—
External-Upset Drill Pipe												
2 ³ / ₈	6.65	2.375	0.280	1.815	6.26	4.60	2.656	1 ⁹ / ₁₆	4 ¹ / ₄	—	3	5 ¹ / ₂
2 ⁷ / ₈	10.40	2.875	0.362	2.151	9.72	6.20	3.250	1 ¹⁵ / ₁₆	4 ¹ / ₄	—	3	5 ¹ / ₂
3 ¹ / ₂	13.30	3.500	0.368	2.764	12.31	10.20	4.000	2 ¹ / ₂	4 ¹ / ₄	—	3	5 ¹ / ₂
3 ¹ / ₂	15.50	3.500	0.449	2.602	14.63	8.20	4.000	2 ¹ / ₂	4 ¹ / ₄	—	3	5 ¹ / ₂
4	14.00	4.000	0.330	3.340	12.93	14.40	4.625	3 ¹ / ₁₆	4 ¹ / ₄	—	3	5 ¹ / ₂
4 ¹ / ₂	16.60	4.500	0.337	3.826	14.98	17.20	5.188	3 ⁹ / ₁₆	4 ¹ / ₄	—	3	5 ¹ / ₂
4 ¹ / ₂	20.00	4.500	0.430	3.640	18.69	16.00	5.188	3 ⁷ / ₁₆	4 ¹ / ₄	—	3	5 ¹ / ₂
5	19.50	5.000	0.362	4.276	17.93	21.60	5.750	3 ¹⁵ / ₁₆	4 ¹ / ₄	—	3	5 ¹ / ₂
5	25.60	5.000	0.500	4.000	24.03	21.20	5.875	3 ¹³ / ₁₆	4 ¹ / ₄	—	3	5 ¹ / ₂
Internal-External-Upset Drill Pipe												
3 ¹ / ₂	15.50	3.500	0.449	2.602	14.63	11.00	3.781	1 ¹⁵ / ₁₆	4 ¹ / ₄	—	3	5 ¹ / ₂
4 ¹ / ₂	16.60	4.500	0.337	3.826	14.98	8.70	4.750	2 ⁷ / ₈	2 ¹ / ₂	3	1 ¹ / ₂	3
4 ¹ / ₂	20.00	4.500	0.430	3.640	18.69	17.60	4.781	2 ¹³ / ₁₆	4 ¹ / ₄	3	3	5 ¹ / ₂
5	19.50	5.000	0.362	4.276	17.93	16.80	5.188	3 ⁹ / ₁₆	4 ¹ / ₄	3	3	5 ¹ / ₂
5	25.60	5.000	0.500	4.000	24.03	15.40	5.188	3 ⁵ / ₁₆	4 ¹ / ₄	3	3	5 ¹ / ₂
5 ¹ / ₂	21.90	5.500	0.361	4.778	19.81	21.00	5.750	3 ¹³ / ₁₆	4 ¹ / ₄	3	3	5 ¹ / ₂
5 ¹ / ₂	24.70	5.500	0.415	4.670	22.54	18.40	5.750	3 ¹³ / ₁₆	4 ¹ / ₄	3	3	5 ¹ / ₂
6 ⁵ / ₈	25.20	6.625	0.330	5.965	22.19	25.87	7.000	5.315	4 ¹ / ₂	3	3	5 ¹ / ₂
6 ⁵ / ₈	27.70	6.625	0.362	5.901	24.21	24.00	7.000	5.315	4 ¹ / ₂	3	3	5 ¹ / ₂

^aDesignations (Column 1) are shown for the purpose of identification in ordering.

^bFor internal-upset drill pipe, the tolerance on the outside diameter of the upset, *D_{ou}*, shall be + ¹/₈, - 0 in. A slight external upset within these tolerances is permissible.

^cMaximum taper on inside diameter of internal upset and internal-external upset is ¹/₄ in./ft on diameter.

^dWeight gain or loss due to end finishing. See 8.4.

^eThe specified upset dimensions do not necessarily agree with the bore and OD dimensions of finished weld-on assemblies. Upset dimensions were chosen to accommodate the various bores of tool joints and to maintain a satisfactory cross section in the weld zone after final machining of the assembly.

^f*L_{iu}* tolerance for 6⁵/₈ weights is + 2, - ¹/₂ in.

Notes:

1. See Figure 4.
2. See Appendix A for metric tables.

Table 9—Tolerances on Dimensions and Weights
(See Appendix A for Metric Tables)

Outside Diameter, <i>D</i>	Tolerance
Size 4 and smaller.....	± 0.031 in.
Size 4½ and larger.....	+ 1.00% - 0.50%

Carloads, 40,000 lbs. or more.....	- 1.75%
Carloads, less than 40,000 lbs.	- 3.5%
Order items, 40,000 lbs.	- 1.75%
Order items, less than 40,000 lbs.....	- 3.5%

The following tolerance apply to the outside diameter of the drill pipe body immediately behind the upset for a distance of approximately 5 in. for sizes 5½ and smaller, and a distance approximately equal to the OD for sizes larger than 5½. Measurements shall be made with calipers or snap gages.

Inside Diameter: *d*, is governed by the outside diameter and weight tolerances.

Upset Dimensions:

Tolerances on upset dimensions are given in Tables 7 and 8.

Pipe Size	Behind <i>m_{eu}</i> , in.	
2.375–3.500	+ 3/32	- 1/32
4.000–5.000	+ 7/64	- 0.75% <i>D</i>
5.500–6.625	+ 1/8	- 0.75% <i>D</i>

Eccentricity:

Outside Diameter:

The maximum eccentricity, measured with a saddle gage (see Figure 5) at a distance of 5 to 6 in. from the end of the upset, shall not exceed 0.093 in. (total indicator reading).

Inside Diameter:

The maximum eccentricity of the bore of the upset with respect to the outside surface of the drill pipe shall not be more than 1/16 in. (1/8 in. total indicator reading).

Wall Thickness, *t* - 12.5 percent

Weight:

Single lengths + 6.5 percent
..... - 3.5 percent

Ovality:

Maximum ovality, measured with a micrometer on outside diameter of upset shall not exceed 0.093 in.

Range Lengths—All lengths in feet

	Range:	1	2	3
Total range length, incl.		18–22	27–30	38–45
^a Range length for 95% or more of carload:				
Permissible variation, max.		2	—	—
Permissible length, min.		20	—	—
^a Range length for 90% or more of carload:				
Permissible variation, max.		—	2	3
Permissible length, min.		—	27	38

^aCarload tolerances shall not apply to order items of less than 40,000 lbs of pipe. For any carload of 40,000 lbs or more of pipe is shipped to the final destination without transfer or removal from the car, the tolerance shall apply to each car. For any order item consisting of 40,000 lbs or more of pipe that is shipped from the manufacturer's facility by rail, but not to the final destination, the carload tolerance shall apply to the overall quantity of pipe shipped on the order item, but not to individual carloads.

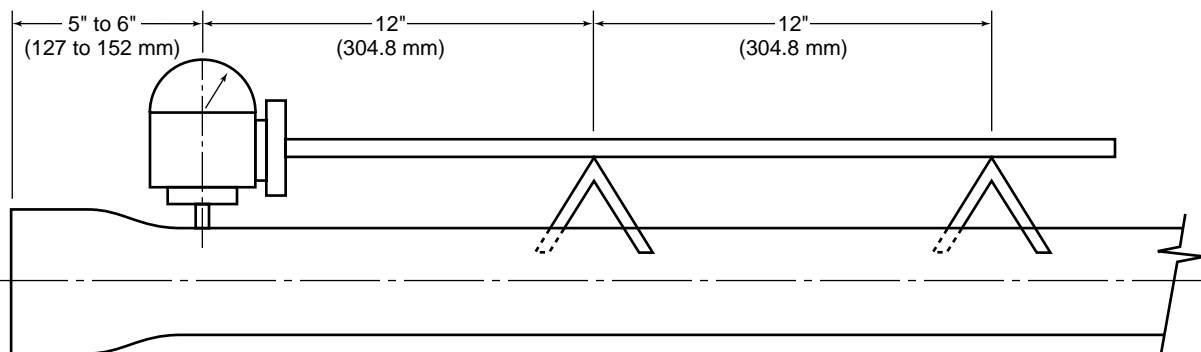

Figure 5—Saddle Gage for Measuring Eccentricity of Drill Pipe

Table 10—Drill Pipe Upset
Maximum Permissible Depth of Imperfections
(Measured from the Surface)

Surface	Depth	Measurement Notes
1. All surfaces from the planes as specified in 2 and 3 below throughout the upset interval.	12.5%	Percent of specified pipe body wall thickness; for nonlinear imperfections; for all grades of pipe.
	12.5%	Percent of specified pipe body wall thickness; for linear imperfections; for Grade E-75 pipe.
	5%	Percent of specified pipe body wall thickness; for linear imperfections; for Grades X-95, G-105, and S-135 pipe.
2. On the external upset surface from the end of the pipe to a plane at a distance equal to the specified minimum dimension L_{eu} (Figures 3 and 4) from the end of the pipe, maximum permissible depth is as indicated by the requirement for maintaining dimension D_{ou} .		
3. On the internal upset surface from the end of the pipe to a plane at a distance equal to the specified minimum dimension L_{iu} (Figures 3 and 4) from the end of the pipe, maximum permissible depth is as indicated by the requirement for maintaining dimension d_{ou} .		
4. The minimum wall thickness in the upset taper interval, and the maximum combined effect of coincident internal and external imperfections in all areas, shall not result in less than 87.5% of the specified pipe wall thickness.		
5. Elephant hide in the outside diameter exposed surfaces shall be inspected in accordance with Item 1 tolerances above.		

9 Pipe Ends

9.1 GENERAL

Drill pipe shall be furnished with upset ends for attachment of rotary connections by welding, unless otherwise agreed on by the purchaser and manufacturer, in which case all stipulations herein, other than end finish and calculated weights, shall govern. The inside and outside edges of the ends of all pipe shall be free of burrs.

Note: Special marking as shown in Section 11 is required for drill pipe furnished with plain ends or end finished not specified herein, but having the body of the pipe manufactured in accordance with the requirements specified herein.

10 Pipe Inspection

10.1 GENERAL

10.1.1 Introduction

This section establishes requirements for the nondestructive inspection (including visual inspection) and disposition of pipe covered in this specification.

10.1.2 Purchaser Inspection

When stated on the purchase order, the provisions of Appendix C shall apply.

10.2 INSPECTION REQUIREMENTS

The manufacturer shall inspect the pipe body using the methods required by Table 11 in accordance with 10.6, or by other inspection methods that have demonstrated the capability of detecting defects as defined in 8.8. The location of the equipment shall be at the discretion of the manufacturer; however, nondestructive inspection (excluding the visual method and pipe body wall thickness verification, see 10.4) shall take place after all heat treating and rotary straightening operations.

10.3 PIPE INSPECTION COVERAGE

10.3.1 Pipe Body

All pipe requiring nondestructive inspection (excluding the visual method) shall be inspected full length (end to end) for outside and inside surface defects.

10.3.2 End Area

When an automated ultrasonic or electromagnetic inspection system (combined equipment, operating procedures, and personnel) is applied to meet the requirements of 10.3.1, end areas that are not covered by the automated inspection system shall be inspected for defects by the magnetic particle method or other inspection method with demonstrated capability of detecting defects as defined in 8.8.

Such end area inspection shall be performed after final heat treatment and any rotary straightening; however, it need only be performed once. The combination of inspection methods shall inspect 100% of the outside and inside surfaces.

10.3.3 Pipe Upsets

Forged upsets (including the upset runout interval) on all grades shall be inspected for outside and inside transverse surface defects by any of the methods listed in 10.6 and shall take place after all heat treating and rotary straightening.

10.4 PIPE BODY WALL THICKNESS VERIFICATION

All drill pipe requiring electromagnetic or ultrasonic inspection per Table 11, shall have the wall thickness verified in a helical or longitudinal path over the length of the pipe, excluding end areas not covered by automated systems. The location and procedure of this verification process shall be at the discretion of the manufacturer.

10.5 VISUAL INSPECTION

10.5.1 Visual Inspection of the Pipe Body (Excluding Pipe Ends)

Each pipe shall be visually inspected for defects on the entire outside surface.

10.5.2 Visual Inspection of Pipe Ends

10.5.2.1 Pipe ends shall be visually inspected on the outside surface for a minimum distance of 18 in.

10.5.2.2 Pipe ends shall be visually inspected on the inside surface for a minimum distance equal to the length of upset, including run-out interval.

10.5.2.3 If another method is applied with demonstrated capability of detecting defects as defined in 8.8, visual inspection of the ends is not required.

10.5.2.4 If cropping is performed per 10.12.2, the inside surface shall again be inspected per 10.5.2.

10.6 STANDARD PROCEDURE FOR INSPECTION

For other than wall thickness verification and visual inspection, the inspections shall be performed, as a minimum, in accordance with the applicable ASTM standards (or equivalent standards) listed below:

- a. Electromagnetic (Flux Leakage)..... E570
- b. Electromagnetic (Eddy-Current)..... E309
- c. Ultrasonic..... E213

Table 11—Pipe Body Inspection Methods

	1	2	3	4	5
					MPI (Circular Field)
Grade		Visual	EMI	UT	
E-75		R	A	A	A
X-95, G-105, S-135		R	A	A	—

R = Required per 10.5.

— (dash) = Not Applicable.

A = One method or any combination of methods shall be used.

- d. Magnetic Particle..... E709
- e. Liquid Penetrant E165

10.7 REFERENCE STANDARDS

10.7.1 Ultrasonic and electromagnetic inspection systems for other than wall thickness verification shall use reference standards containing notches or holes as shown in Table 12 to verify equipment response from artificial reference indicators.

10.7.2 The manufacturer may use any documented procedures to establish the reject threshold for ultrasonic or electromagnetic inspection, provided the artificial reference indicators described in Table 12 can be detected dynamically under normal operating conditions. Such detection capability shall be demonstrated dynamically. At the option of the manufacturer, this may be performed either on-line or off-line.

10.7.3 Table 12 lists the reference indicators for manufacturers to use in establishing thresholds for sorting pipe that may contain defects as defined in 8.8. The reference indicators, used during automated ultrasonic or electromagnetic inspection, are not to be construed as being the defect sizes defined in 8.8, or be used by those other than the manufacturer as the only basis for rejection.

10.8 AUTOMATED INSPECTION SYSTEM SIGNAL EVALUATION

All indications that are equal to or greater than the reject threshold shall be considered defects, unless it can be demonstrated that the imperfection causing the indication is not a defect as described in 8.8. Pipe with defects shall be given a disposition in accordance with 10.12.

10.9 RECORDS VERIFYING SYSTEM CAPABILITY

Inspection system records shall be maintained to verify the system capabilities in detecting reference indicators as stated in 10.7. These records shall include calibration and operating procedures, equipment description, personnel qualifications, and dynamic test data demonstrating the system capabilities for detecting the reference indicators.

Table 12—Artificial Reference Indicators

1	2	3	4	5	6	7	8	9
Grade	Notch Location		Notch Orientation ^a		Notch Dimensions			Radially Drilled Hole ^c
Pipe Body	OD	ID	Long.	Trans.	Depth ^b	Length Max., in. at Full Depth	Width Max., in. at Full Depth	Diameter
E-75	R	R	R	N	12.5	2.0	.040	1/8
X-95 and G-105	R	R	R	R	12.5	2.0	.040	1/8
S-135	R	R	R	R	5.0	2.0	.040	1/16

R = Required when using notches.

N = Not Required

^aNotches shall be rectangular or U-shaped per ASTM E213, Figure 2, Common Notch Shapes. At the option of the manufacturer, notches may be oriented at such an angle as to optimize detection of anticipated defects.

^bDepth as a percent of specified wall thickness. The depth tolerance shall be $\pm 15\%$ of the calculated notch depth with a minimum notch depth of $0.012" \pm 0.002"$ (0.3 ± 0.5 mm).

^cDrilled hole diameter (through the pipe wall) shall be used on drill bit sizes in inches. When calibrating EMI equipment using drilled holes, the inspection system shall be capable of producing signals from both ID and OD notches that are equal to or greater than the reject threshold established using the drilled hole. This system capability shall be recorded per 10.9.

Note: The reference indicators defined above are convenient for verification of nondestructive testing equipment response. The dimensions of the notches or holes should not be construed as the minimum size imperfections detectable by such equipment. The inspections performed in accordance with 10.2, with the equipment calibrated to the reference indicators in Table 12, should not be construed as assuring that the material requirements in 8.8 have been met.

10.10 CERTIFICATION AND QUALIFICATION OF PERSONNEL

As a minimum, ASNT Recommended Practice SNT-TC-1A or equivalent shall be the basis for certification for nondestructive testing (NDT) personnel. Inspections (excluding the visual method) shall be conducted by Level I, II or III certified inspectors.

10.11 EVALUATION OF INDICATIONS (PROVE-UP)

The manufacturer has the option of evaluating an indication, which is equal to or greater than the reject threshold, in accordance with this paragraph or disposing of the indication as a defect per 10.12. Evaluations of indications shall be performed by Level I certified inspectors under the supervision of Level II or III certified inspectors, or by Level II or III certified inspectors. Evaluation of indications shall be performed in accordance with written procedures. For the evaluation of an indicated imperfection, the depth shall be measured to determine if it is a defect in accordance with 8.8. This measurement shall be performed as follows:

a. The imperfection's depth may be measured using a mechanical measuring device (e.g., pit gauge, calipers, etc.). Removal of material by grinding or other means to facilitate measurement shall not reduce the remaining wall below

87.5% of the specified wall thickness. Abrupt changes in wall thickness caused by probe grinding shall be removed.

b. The imperfection's depth may be measured by an ultrasonic technique(s) (time and/or amplitude based, or other capable techniques). Verification of the ultrasonic technique(s) shall be documented, and show capability to differentiate imperfection sizes larger than the appropriate defect size stated in 8.8.1 and 8.8.2.

c. If the purchaser and manufacturer do not agree on the evaluation test results, either party may require destructive evaluation of the material; after which, accountability shall be as described in C.4.

d. Imperfections that have been evaluated and found to be defects shall be given a disposition in accordance with 10.12.

10.12 DISPOSITION

Imperfections that satisfy the material requirements and are less than the defect size stated in 8.8 are allowed to remain in the pipe. Repair welding is not permitted. Pipe containing defects shall be given one of the following dispositions:

10.12.1 Grinding or Machining

Defects shall be completely removed by grinding or machining, provided the remaining wall thickness is within specified limits. Generous radii shall be used to preclude

abrupt changes in wall thickness. Where the depth of the grind exceeds 10% of the specified wall thickness, the remaining wall thickness shall be verified in accordance with 7.4.2. After removal of the defect, the affected area shall be reinspected by one or more of the nondestructive inspection methods specified in 10.6 to verify complete removal of the defect. The manufacturer's documented prove-up procedures shall address the possibility that there may be other coincident defects in the affected area. The removal of imperfections (including elephant hide) from the pipe body by grinding or machining more than 60% of the circumference of the pipe shall not reduce the outside diameter below the specified minimum outside diameter.

10.12.2 Cut-off

The section of pipe containing the defect shall be cut-off within the limits of requirements on length of the intended product.

10.12.3 Rejected

The pipe shall be rejected.

11 Marking and Coatings

11.1 GENERAL

Drill pipe manufactured in conformance with this specification shall be marked by the manufacturer as specified hereinafter. Marking shall be die stamped or paint stenciled, or both, as stipulated, unless otherwise agreed upon between the purchaser and the manufacturer. The location, size, and sequence of markings shall be as specified in 11.3 and 11.4, except that, at the option of the manufacturer, hot-rolled or hot-stamped markings on pipe and couplings may be substituted for die-stamped markings and are permitted at intervals along the length. Additional markings, including those for applicable compatible standards as desired by the manufacturer, or as requested by the purchaser, are not prohibited. Markings shall not overlap and shall be applied in such manner as not to injure the pipe.

11.2 PIPE MARKINGS

Markings for drill pipe and methods of application shall be as follows:

11.2.1 Manufacturer's Name or Mark

The manufacturer's name or mark shall be die stamped unless otherwise agreed upon between the purchaser and the manufacturer—in which case it shall be paint stenciled.

11.2.2 "Spec 5D"

"Spec 5D" shall be die stamped, unless otherwise agreed upon between the purchaser and the manufacturer—in which case it shall be paint stenciled. The "Spec 5D" identity shall be applied only as specified and only by manufacturers who meet all requirements of this specification.

Note: Users of this specification should note that there is no longer a requirement for marking a product with the API monogram. The American Petroleum Institute continues to license use of the monogram on products covered by this specification but it is administered by the staff of the Institute separately from the specification. The policy describing use of the monogram is contained in Appendix D herein. No other use of the monogram is permitted. Licensees may mark products in conformance with Appendix D or Section 11 and nonlicensees may mark products in conformance with Section 11.

11.2.3 Compatible Standards

Products in compliance with multiple compatible standards may be stamped or stenciled with the name of each standard (at the option of the manufacturer).

11.2.4 Unfinished Pipe

Drill pipe furnished with plain ends or end finishes other than the upsets detailed herein, but having the body of the pipe manufactured in accordance with the requirements specified herein, shall be die stamped with the symbol UF immediately following "Spec 5D," and any applicable compatible standard.

11.2.5 Designation

11.2.5.1 The size and weight designations are dimensionless quantities based on the former U.S. Customary size and weight per foot.

11.2.5.2 The size designation (Column 1, Tables 7 and 8) shall be paint stenciled.

11.2.5.3 The weight designation, as given in Tables 7 and 8, shall be die stamped and paint stenciled.

11.2.6 Grade

The grade marking shall be die stamped and paint stenciled as follows:

Grade E-75	E
Grade X-95	X
Grade G-105	G
Grade S-135	S

11.3 DIE-STAMPED MARKINGS

11.3.1 Die-stamped markings shall be placed on the outside surface of the upset portion of either end. The size of die-stamped marking shall be as follows:

Size of Pipe	Size of Markings	
	in.	mm
Pipe 4 and under	3/16	4.8
Pipe 4 1/2 and over	1/4	6.4

11.3.2 The sequence of die-stamped markings shall be as follows:

- Manufacturer’s name or mark11.2.1
- Spec 5D11.2.2
- Compatible Standards.....11.2.3
- Symbol UF.....11.2.4
- Weight designation11.2.5
- Grade11.2.6

Example:

Size 2 3/8, weight 6.65, grade E plain-end drill pipe shall be die stamped as follows:

AB CO Spec 5D UF 6.65 E

11.4 PAINT-STENCILED MARKINGS

Paint-stenciled markings shall be placed on the outside surface of each length of pipe starting not less than 24" (610 mm) from either end of plain-end pipe. The sequence of paint-stenciled markings shall be as follows:

- Size designation11.2.5
- Weight designation11.2.5
- Grade11.2.6

Example:

Size 5, weight 19.50; grade G-105 drill pipe shall be paint stenciled as follows:

5 19.50 G

11.5 PIPE PROCESSOR MARKINGS

Pipe heat treated by a processor other than the original pipe manufacturer shall be marked as stipulated in 11.1, 11.2, 11.3, and 11.4. The processor shall remove any identity

which is not indicative of the new condition of the product as a result of heat treating (i.e., prior grade identity, original pipe manufacturer’s name or logo).

11.6 COATINGS

Unless otherwise ordered, pipe shall be given an external coating for protection from rust while in transit. An attempt should be made to make these coatings smooth, hard to the touch, and with minimum sags.

Note: If bare pipe or specially coated pipe is desired, the purchase order should so state. For special coatings, the purchase order should state further whether the coating is to be applied to the full length or whatever a certain specific distance from the end is to be left uncoated. Unless otherwise specified, such bare ends are commonly given a coating with oil for protection in transit.

12 Minimum Facility Requirements for Various Categories of Manufacturers

12.1 PIPE MILL

12.1.1 A pipe mill shall operate one or more pipe-making facilities capable of producing products as described in the Process of Manufacture Section of this specification.

12.1.2 A pipe mill shall also have facilities for conducting all required tests and inspections. Alternatively, and at the option of the pipe mill, any of these tests or inspections may be provided by a third party and may be located offsite. In the event that a third party performs any of these services, the conduct of such inspections and tests shall be controlled and monitored by the pipe mill in accordance with a documented procedure.

12.1.3 The pipe mill shall possess suitable equipment for, and be responsible for, weighing and marking pipe.

12.2 PROCESSOR

12.2.1 A processor shall operate heat-treating facilities capable of heat treating full lengths of pipe. A processor shall also have facilities for conducting all required tests and inspections. Alternatively, and at the option of the processor, any of these tests or inspections may be provided by a third party and may be located offsite. In the event that a third party performs any of these services, the conduct of such inspections and tests shall be controlled and monitored by the processor in accordance with a documented procedure.

12.2.2 The processor shall possess suitable equipment for, and be responsible for, weighing and marking pipe.

APPENDIX A—METRIC TABLES

The following tables provide the metric equivalents of U.S. Customary values for dimensions and weights.

Note: Metric tables will be revised in the next edition of Spec 5D to conform to changes made in Section 8. Use the metric conversion factors in 1.2 where necessary.

**Table A-1—Upset Drill Pipe for Weld-on Tool Joints—Dimensions and Weights (Group 1)
Metric (From Table 7)**

1		2		3		4		5		6		7		8		9		10		11		12		13	
Designations ¹		Outside Diameter mm	Wall Thickness		Inside Diameter mm	Plain End kg/m	Upset ^d kg	Outside Diameter ^b +3.18 -0.79	Inside Diameter at End of Pipe, ^c ±1.59	Length of Internal Upset ^e +38.10 ^h -12.70	Length of Internal Taper, ^g Min.	Length of External Upset, Min.	Length of External Taper		Length End of Pipe to Taper Fadeout, Max.										
			in.	mm									Min.	Max.											
Size	Weight	<i>D</i>	<i>t</i>		<i>d</i>	<i>w_{pe}</i>	<i>e_w</i>	<i>D_{ou}</i>	<i>d_{ou}</i>	<i>L_{iu}</i>	<i>m_{iu}</i>	<i>L_{eu}</i>	<i>m_{eu}</i>		<i>L_{eu} + m_{eu}</i>										
Internal-Upset Drill Pipe																									
2 ⁷ / ₈	10.40	73.0	0.362	9.2	54.6	14.47	1.45	73.0	33.3	44.4	38.1	—	—	—	—										
3 ¹ / ₂	9.50	88.9	0.254	6.4	75.9	13.21	2.00	88.9	57.2	44.4	—	—	—	—											
3 ¹ / ₂	13.30	88.9	0.368	9.3	70.3	18.26	2.00	88.9	49.2	44.4	38.1	—	—	—											
3 ¹ / ₂	15.50	88.9	0.449	11.4	66.1	21.79	1.54	88.9	49.2	44.4	38.1	—	—	—											
*4	11.85	101.6	0.262	6.6	88.2	15.68	1.91	101.6	74.6	44.4	—	—	—	—											
4	14.00	101.6	0.330	8.4	84.8	19.31	2.09	107.9	69.8	44.4	50.8	—	—	—											
*4 ¹ / ₂	13.75	114.3	0.271	6.9	100.5	18.27	2.36	120.6	85.7	44.4	—	—	—	—											
*5	16.25	127.0	0.296	7.5	112.0	22.10	3.00	127.0	95.2	44.4	—	—	—	—											
External-Upset Drill Pipe																									
2 ³ / ₈	6.65	60.3	0.280	7.1	46.1	9.31	0.82	67.5	46.1	—	—	38.1	38.1	—	101.6										
2 ⁷ / ₈	10.40	73.0	0.362	9.2	54.6	14.47	1.09	81.8	54.6	—	—	38.1	38.1	—	101.6										
3 ¹ / ₂	9.50	88.9	0.254	6.4	75.9	13.21	1.18	100.0	76.0	—	—	38.1	38.1	—	101.6										
3 ¹ / ₂	13.30	88.9	0.368	9.3	70.3	18.26	1.82	100.0	66.1	57.2	50.8	38.1	38.1	—	101.6										
3 ¹ / ₂	15.50	88.9	0.449	11.4	66.1	21.79	1.27	100.0	66.1	—	—	38.1	38.1	—	101.6										
*4	11.85	101.6	0.262	6.6	88.2	15.68	2.27	114.3	88.3	—	—	38.1	38.1	—	101.6										
4	14.00	101.6	0.330	8.4	84.8	19.31	2.27	115.9	84.8	—	—	38.1	38.1	—	101.6										
*4 ¹ / ₂	13.75	114.3	0.271	6.9	100.5	18.27	2.54	128.6	100.5	—	—	38.1	38.1	—	101.6										
4 ¹ / ₂	16.60	114.3	0.337	8.6	97.1	22.42	2.54	128.6	97.2	—	—	38.1	38.1	—	101.6										
4 ¹ / ₂	20.00	114.3	0.430	10.9	92.5	27.79	2.54	128.6	92.5	—	—	38.1	38.1	—	101.6										
Internal-External-Upset Drill Pipe																									
4 ¹ / ₂	16.60	114.3	0.337	8.6	97.1	22.42	3.68	120.6	80.2	63.5	50.8	38.1	25.4	38.1	—										
4 ¹ / ₂	20.00	114.3	0.430	10.9	92.5	27.79	3.90	121.4	76.2	57.2	50.8	38.1	25.4	38.1	—										
5	19.50	127.0	0.362	9.2	108.6	26.73	3.90	131.8	93.7	57.2	50.8	38.1	25.4	38.1	—										
5	25.60	127.0	0.500	12.7	101.6	35.80	3.51	131.8	87.3	57.2	50.8	38.1	25.4	38.1	—										
5 ¹ / ₂	21.90	139.7	0.361	9.2	121.3	29.61	4.81	146.0	101.6	57.2	50.8	38.1	25.4	38.1	—										
5 ¹ / ₂	24.70	139.7	0.415	10.5	118.7	33.45	4.09	146.0	101.6	57.2	50.8	38.1	25.4	38.1	—										
6 ⁵ / ₈	25.20	168.3	0.330	8.4	151.5	—	—	177.8	135.0	114.3	50.8	76.2	—	—	139.7										
6 ⁵ / ₈	27.70	168.3	0.362	9.2	149.9	—	—	177.8	135.0	114.3	50.8	76.2	—	—	139.7										

^aDesignations (Column 1) are shown for the purpose of identification in ordering.

^bFor internal-upset drill pipe, the tolerance on the outside diameter of the upset, *D_{ou}*, shall be + 3.18 – 0 mm. A slight external upset within these tolerances is permissible.

^cMaximum taper on inside diameter of internal upset and internal-external upset is 20.8 mm/m (2.08%) on diameter.

^dWeight gain or loss due to end finishing. See 8.4.

^eThe specified upset dimensions do not necessarily agree with the bore and OD dimensions of finished weld-on assemblies. Upset dimensions were chosen to accommodate the various bores of tool joints and to maintain a satisfactory cross section in the weld zone after final machining of the assembly.

^fBy agreement between purchaser and manufacturer or processor, the length of upset for Grade E drill pipe may be the same as for the higher grades in Group 3.

^g3¹/₂" OD x 13.3 lb/ft External-Upset Drill Pipe has a slight internal upset not illustrated in Figure 4.

^h*L_{iu}* tolerance for 6⁵/₈ weights is + 50.8, – 12.7 mm.

*These sizes and weights are tentative.

Note: See Figure 3.

Table A-2—Upset Drill Pipe for Weld-on Tool Joints—Dimensions and Weights (Group 3)
Table Metric (From Table 8)

1		2		3		4		5		6		7		8		9		10		11		12							
		Calculated Weight						Upset Dimensions, in. ^{e,f}																					
Designations ^a		Outside Diameter	Wall Thickness		Inside Diameter	Plain End	Upset ^d	Outside Diameter ^b	Inside Diameter at End of Pipe, ^c	Length of Internal Upset	Length of Internal Taper, Min.	Length of External Upset, Min.	Length of External Taper, Min.	Length End of Pipe to Taper Fadeout, Ext. Upset Max.															
Size	Weight	<i>D</i>	in.	mm	<i>d</i>	<i>w_{pe}</i>	<i>e_w</i>	+3.18 −0.79	±1.59	+38.10 −12.70	<i>L_{iu}</i>	<i>m_{iu}</i>	<i>L_{eu}</i>	<i>L_{eu} + m_{eu}</i>															
Internal-Upset Drill Pipe																													
2 ⁷ / ₈	10.40	73.0	0.362	9.2	54.6	14.47	2.45	73.0	33.4	88.9	—	—	—	—															
3 ¹ / ₂	13.30	88.9	0.368	9.3	70.3	18.26	3.36	88.9	49.2	88.9	—	—	—	—															
4	14.00	101.6	0.330	8.4	84.8	19.31	4.00	107.9	66.8	88.9	—	—	—	—															
5	16.25	127.0	0.296	7.5	112.0	22.10	6.17	127.0	90.5	88.9	—	—	—	—															
External-Upset Drill Pipe																													
2 ³ / ₈	6.65	60.3	0.280	7.1	46.1	9.31	2.09	67.5	39.7	108.0	—	76.2	139.7																
2 ⁷ / ₈	10.40	73.0	0.362	9.2	54.6	14.47	2.80	82.6	49.2	108.0	—	76.2	139.7																
3 ¹ / ₂	13.30	88.9	0.368	9.3	70.3	18.26	4.63	101.6	63.5	108.0	—	76.2	139.7																
3 ¹ / ₂	15.50	88.9	0.449	11.4	66.1	21.79	3.72	101.6	63.5	108.0	—	76.2	139.7																
4	14.00	101.6	0.330	8.4	84.8	19.31	6.54	117.5	77.8	108.0	—	76.2	139.7																
4 ¹ / ₂	16.60	114.3	0.337	8.6	97.1	22.42	7.81	131.8	90.5	108.0	—	76.2	139.7																
4 ¹ / ₂	20.00	114.3	0.430	10.9	92.5	27.79	7.26	131.8	87.3	108.0	—	76.2	139.7																
5	19.50	127.0	0.362	9.2	108.6	26.73	9.81	146.1	100.0	108.0	—	76.2	139.7																
5	25.60	127.0	0.500	12.7	101.6	35.80	9.62	149.2	96.9	108.0	—	76.2	139.7																
Internal-External-Upset Drill Pipe																													
3 ¹ / ₂	15.50	88.9	0.449	11.4	66.1	21.79	4.99	96.0	49.2	108.0	—	76.2	139.7																
4 ¹ / ₂	16.60	114.3	0.337	8.6	97.1	22.42	3.95	120.6	73.0	63.5	76.2	38.1	76.2																
4 ¹ / ₂	20.00	114.3	0.430	10.9	92.5	27.79	7.99	121.4	71.5	108.0	76.2	76.2	139.7																
5	19.50	127.0	0.362	9.2	108.6	26.73	7.63	131.8	90.5	108.0	76.2	76.2	139.7																
5	25.60	127.0	0.500	12.7	101.6	35.80	6.99	131.8	84.2	108.0	76.2	76.2	139.7																
5 ¹ / ₂	21.90	139.7	0.361	9.2	121.3	29.61	9.53	146.0	96.9	108.0	76.2	76.2	139.7																
5 ¹ / ₂	24.70	139.7	0.415	10.5	118.7	33.45	8.35	146.0	96.9	108.0	76.2	76.2	139.7																
6 ⁵ / ₈	25.20	168.3	0.330	8.4	151.5	—	—	177.8	135.0	114.3	76.2	76.2	139.7																
6 ⁵ / ₈	27.70	168.3	0.362	9.2	149.9	—	—	177.8	135.0	114.3	76.2	76.2	139.7																

^aDesignations (Column 1) are shown for the purpose of identification in ordering.

^bFor internal-upset drill pipe, the tolerance on the outside diameter of the upset, *D_{ou}*, shall be 3.18, −0 mm. A slight external upset within these tolerances is permissible.

^cMaximum taper on inside diameter of internal upset and internal-external upset is 20.8 mm/m (2.08%) on diameter.

^dWeight gain or loss due to end finishing. See 8.4.

^eThe specified upset dimensions do not necessarily agree with the bore and OD dimensions of finished weld-on assemblies. Upset dimensions were chosen to accommodate the various bores of tool joints and to maintain a satisfactory cross section in the weld zone after final machining of the assembly.

^f*L_{iu}* tolerance for 6⁵/₈ weights is + 50.8, − 12.7 mm.

Note: See Figure 4.

Table A-3—Tolerances on Dimensions and Weights
Metric (From Table 9)

	Outside Diameter, <i>D</i>	
	Tolerance	
Size 4 in. and smaller	± 0.79 mm	
Size 4 ¹ / ₂ and larger	+ 1.00%	
	- 0.50%	

The following tolerance apply to the outside diameter of the drill pipe body immediately behind the upset for a distance of approximately 127 mm. Measurements shall be made with calipers or snap gages.

Pipe Size, OD in.	Tolerances Behind <i>m_{eu}</i> or <i>L_o</i> , mm	
2.375–3.500	+ 2.38	- 0.79
4.000–5.000	+ 2.78	- 0.75% <i>D</i>
5.500–6.625	+ 3.18	- 0.75% <i>D</i>

Wall Thickness, *t*..... - 12.5%

Weight:
Single lengths..... + 6.5%
..... - 3.5%

Carloads, 18,144 kg or more..... - 1.75%
Carloads, less than 18,144 kg..... - 3.5%
Order items, 18,144 kg or more..... - 1.75%
Order items, less than 18,144 kg..... - 3.5%

Inside Diameter: *d*, is governed by the outside diameter and weight tolerances.

Upset Dimensions:
Tolerances on upset dimensions are given in Tables A-1 and A-2.

Eccentricity:
Outside Diameter:
The maximum eccentricity, measured with a saddle gage (see Figure 5) at a distance of 127 to 152 mm from the end of the upset, shall not exceed 2.36 mm (total indicator reading).

Inside Diameter:
The maximum eccentricity of the bore of the upset with respect to the outside surface of the drill pipe shall not be more than 1.59 mm (3.18 mm total indicator reading).

Ovality:
Maximum ovality, measured with a micrometer on outside diameter of upset shall not exceed 2.36 mm.

Range Lengths—All lengths in meters

	Range:	1	2	3
Total range length, incl.		5.49–6.71	8.23–9.14	11.58–13.72
^a Range length for 95% or more of carload:				
Permissible variation, max.		0.61	—	—
Permissible length, min.		6.10	—	—
^a Range length for 90% or more of carload:				
Permissible variation, max.		—	0.61	0.91
Permissible length, min.		—	8.23	11.58

^aCarload tolerances shall not apply to order items of less than 18,144 kg of pipe. For any carload of 18,144 kg or more of pipe is shipped to the final destination without transfer or removal from the car, the tolerance shall apply to each car. For any order item consisting of 18,144 kg or more of pipe that is shipped from the manufacturer's facility by rail, but not to the final destination, the carload tolerance shall apply to the overall quantity of pipe shipped on the order item, but not to individual carloads.

APPENDIX B—SUPPLEMENTARY REQUIREMENTS

By agreement between the purchaser and manufacturer and when specified on the purchase order, the following supplementary requirements shall apply.

SR2 Nondestructive Inspection (N5 Notch or 1/16-in. Hole)

SR2.1 SUPPLEMENTARY NONDESTRUCTIVE INSPECTION

By agreement between purchaser and manufacturer, and when specified on the purchase order, drill pipe shall be inspected full length for longitudinal defects by either magnetic particle inspection or by ultrasonic or electromagnetic methods, and on the ends of upset pipe for transverse defects by the magnetic particle method. The location of the equipment shall be at the discretion of the manufacturer; however, the nondestructive inspection must take place after final heat treatment and any subsequent rotary-straightening operation.

SR2.2 MAGNETIC PARTICLE INSPECTION

When magnetic particle inspection is employed to inspect for longitudinal defects, the entire outside surface and the inside surface for a distance of 6 in. (152.4 mm) shall be inspected. The outside and inside surfaces of the ends of upset pipe shall be inspected for transverse defects by the magnetic particle method. Magnetic particle inspection of drill pipe may be employed on the inside surface after heat treating and before the ends are cropped. If defects are found, further cropping is permissible provided the inside surface is again inspected by the magnetic particle method, as stipulated above. The depth of all imperfections revealed by magnetic particle inspection shall be determined; and when found to be greater than 5% of the specified wall thickness, the imperfection shall be considered a defect. See SR2.4 for disposition of pipe containing defects.

SR2.3 ULTRASONIC OR ELECTROMAGNETIC INSPECTION

a. Equipment. Any equipment utilizing the ultrasonic or electromagnetic principles and capable of continuous and uninterrupted inspection of the entire surface of the pipe may be used. The equipment shall be of sufficient sensitivity to indicate defects and shall be checked as prescribed in SR2.3b.

b. Reference Standards. A reference standard having the same specified diameter and thickness as the product being inspected shall be used to demonstrate the effectiveness of the inspection equipment and procedures at least once every working turn. The reference standard may be of any convenient length as determined by the manufacturer. It shall be scanned by the inspection unit in a manner stimulating the inspection of the product. For ultrasonic inspection, the refer-

ence standard shall contain a machined notch as specified in Figure SR-2. For electromagnetic inspection, the reference standard shall contain either a machined notch, as specified in Figure SR-2, or a 1/16-in. (1.6 mm) drilled hole. The notch shall be in the outer surface of the reference standard and parallel to the longitudinal axis of the pipe, except for seamless pipe; and at the option of the manufacturer, the notch may be oriented at such an angle as to optimize detection of anticipated defects. The 1/16-in. (1.6 mm) hole shall be drilled radially through the wall of the reference standard. The inspection equipment shall be adjusted to produce a well-defined indication when the reference standard is scanned by the inspection unit.

Note: The dimensions of the machined notches or drilled holes in these standards should not be construed as the minimum size imperfection detectable by such equipment.

Note: Reference standards other than those described above may be used by agreement between the purchaser and manufacturer.

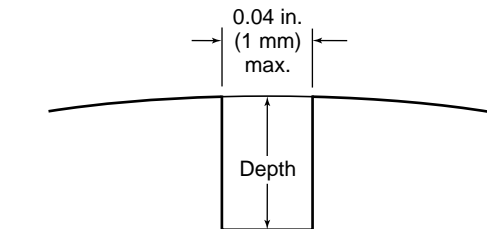

Depth:^a 5%, ± 15% with min. of 0.012, ± 0.002 in. (0.3, ± 0.05 mm)
^aDepth as a percent of specified wall thickness.

Length: For eddy current—1.5 in. (38 mm) max. total length
 For ultrasonic—2 in. (50 mm) min. at full depth.

For diverted flux—The length of notch shall be as required by the equipment design to provide a reproducible signal when the reference standard is passed through the equipment at the inspection line speed for the pipe being inspected. Three passes through the equipment shall be required to ensure reproducibility.

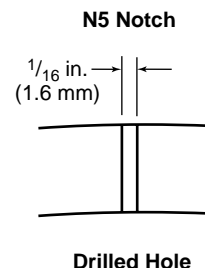

Figure SR-2—Reference Standard

c. Rejection Limits. Any imperfection that produces a signal as great as the signal received from the reference standard shall be considered a defect unless it can be demonstrated by the manufacturer that the imperfection does not exceed the provisions of SR2.4.

SR2.4 DISPOSITION

Imperfections revealed by magnetic particle inspection, and determined to be greater in depth than 5% but not greater than 12¹/₂% of the specified wall thickness, shall be removed by grinding or machining, or the pipe shall be rejected. All imperfections classified as defects by the ultrasonic or electromagnetic equipment, which do not exceed 12¹/₂% of the specified wall thickness in depth, shall be removed by grinding or machining, or the pipe shall be rejected. Pipe with defects, the removal of which requires grinding or machining to a depth in excess of 12¹/₂% of the specified wall thickness, shall be disposed of in accordance with 10.12. Where grinding or machining is done, generous radii shall be used to prevent abrupt changes in wall thickness; and such areas shall be reinspected by one of the nondestructive testing methods specified herein to verify complete removal of the defect.

SR2.5 MARKING

Drill pipe inspected by nondestructive methods as stipulated in SR2.1 through SR2.4 shall be paint stenciled with the letters SR2 at a location convenient to the manufacturer, but near the grade marking.

SR2.6 SUPPLEMENTARY NONDESTRUCTIVE INSPECTION FOR GRADES E-75, X-95, AND G-105

By agreement between purchaser and manufacturer, and when specified on the purchase order, the specified drill pipe shall be inspected for imperfections that are greater than 5% of the specified wall thickness or, which reduce the net effective wall thickness below 87.5% of the specified wall thickness. The imperfections shall be considered defects and shall be given a disposition in accordance with 10.12. The inspection(s), including forged upsets, shall be performed to the minimum requirements stated in Section 10 as for Grade S-135.

SR15 Test Certificates for Oil Country Tubular Goods (OCTG)

SR15.1 The manufacturer shall provide the following data, as applicable, for each item for which this Supplementary Requirement is specified on the purchase order. Manufacturer's certificate shall state the API Specification and revision date thereof, to which pipe was manufactured.

a. Specified diameter, wall thickness, grade, process of manufacture, and type of heat treatment.

b. Chemical analyses (heat, product, and recheck) showing the weight percent of all elements whose limits or reporting requirements are set in this specification.

c. Test data for all tensile tests required by this specification, including yield strength, ultimate tensile strength, elongation. The type, size, and orientation of specimens shall be shown.

d. Impact test results (including the test criteria, and the size, location, and orientation of the test specimen, the nominal test temperature, the absorbed energy measured for each test specimen, the percent shear area, and the average absorbed energy for each test) where such testing is required by the specification.

e. Hardness test results (including test type and criterion, and specimen location and orientation), when such testing is required by the purchaser.

f. For pipe for which nondestructive inspection is specified by the purchaser (either in the base specification, supplementary requirements, or the purchase order), the method of inspection employed (ultrasonic, electromagnetic, or magnetic particle), and the type and size of the reference standard used.

g. Results of any other supplemental testing required by the purchaser.

SR15.2 The manufacturer shall establish and follow procedures for maintaining heat and lot identity of all pipe covered by this Supplementary Requirement. The procedures shall provide means for tracing any length of pipe to the proper heat and lot, and to all applicable chemical and mechanical test results.

SR19 Charpy V-Notch Impact Toughness Testing of Group 1 (Grade E-75) Drill Pipe

SR19.1 SUPPLEMENTARY CHARPY V-NOTCH IMPACT TESTING

By agreement between the purchaser and the manufacturer, and when specified on the purchase order, Grade E-75 drill pipe shall meet the requirements specified in 6.4 of this specification.

SR19.2 TESTING PROCEDURE

The test procedure shall be in accordance with the requirements specified in 7.3 of this specification.

SR19.3 FREQUENCY OF TESTING—GROUP 1 (GRADE E)

When SR19 is specified, three Charpy V-notch specimens representing one test shall be taken from one length of drill pipe from each lot of 400 lengths or less of sizes 5¹/₂ inches and smaller, and from each lot of 200 lengths or less of size

6⁵/₈ inches provided that, in the case of heat treated pipe, all lengths have received the same heat treatment. For multiple length seamless pipe a length shall be considered as all of the sections cut from a particular multiple length.

SR19.4 IMPACT RETEST

If the impact test results fail to meet the requirements in 6.4, the retest provisions on 7.3 shall apply.

SR19.5 MARKING

Drill pipe tested to this supplementary requirement shall be paint stenciled with the letters SR19 at a location convenient to the manufacturer, but near the grade marking.

SR20 Alternate Low Temperature Charpy V-Notch Impact Toughness Testing of Group 1 (Grade E-75) and Group 3 (Grades X-95, G-105, and S-135) Drill Pipe

SR20.1 ALTERNATE LOW TEMPERATURE CHARPY V-NOTCH IMPACT TESTING

By agreement between the purchaser and the manufacturer, and when specified on the purchase order, the Charpy impact testing shall be carried out at 14°F ± 5°F (-10°C ± 2.8°C) and shall meet the requirements of SR20.2.

SR20.2 CHARPY ENERGY REQUIREMENTS

The minimum Charpy V-notch impact energy measured on each of three specimens shall be as listed in Table SR20. The impact energy for each specimen and the average shall be reported.

SR20.3 TESTING PROCEDURE

The test procedure shall be in accordance with the requirements specified in 7.3 of this specification.

SR20.4 FREQUENCY OF TESTING

- a. Group 1: The frequency of testing shall be in accordance with SR19.3.
- b. Group 3: The frequency of testing shall be in accordance with 7.3.4.

SR20.5 IMPACT RETEST

If the impact tests results fail to meet the requirements of SR20.2 the retest, provisions in 7.3.5 shall apply.

SR20.6 MARKING

Drill pipe tested to this supplementary requirement shall be paint stenciled with the letters SR20 at a location convenient to the manufacturer but near the grade marking.

Table SR20—Impact Energy Requirements

1	2		3	
Specimen Size mm x mm	Minimum Average Charpy V-notch Impact Energy of Each Set of Three Specimens ft/lb (J)		Minimum Charpy V-notch Impact Energy of Any Specimen of a Set ft/lb (J)	
10 x 10.0	30	(41)	22	(30)
10 x 7.5	24	(33)	18	(24)
10 x 5.0	20 ^a	(27)	15	(20)

^aBased on 67% of full size.

APPENDIX C—PURCHASER INSPECTION

C.1 Inspection Notice

Where the inspector representing the purchaser desires to inspect this pipe or witness these tests, reasonable notice shall be given of the time when the run is to be made.

C.2 Plant Access

The inspector representing the purchaser shall have unrestricted access at all times while work on the contract of the purchaser is being performed, to all parts of the manufacturer's works which will concern the manufacture of the pipe ordered. The manufacturer shall afford the inspector all reasonable facilities to satisfy that the pipe is being manufactured in accordance with this specification. All inspections should be made at the place of manufacture prior to shipment, unless otherwise specified on the purchase order, and shall be so conducted as not to interfere unnecessarily with the operation of the works.

C.3 Compliance

The manufacturer is responsible for complying with all of the provisions of this specification. The purchaser may make any investigation necessary to satisfy himself of compliance by the manufacturer and may reject any material that does not comply with this specification.

C.4 Rejection

Unless otherwise provided, material which shows defects on inspection or subsequent to acceptance at the manufacturer's works, or which proves defective when properly applied in service, may be rejected, and the manufacturer so notified. If tests that require the destruction of material are made, any product which is proven not to have met the requirements of the specification shall be rejected. Disposition of rejected product shall be a matter of agreement between the manufacturer and the purchaser.

APPENDIX D—USE OF API MONOGRAM MARKING INSTRUCTIONS FOR LICENSEES

D.1 General

Pipe manufactured in conformance with this specification may be marked by the manufacturer as specified hereinafter or specified in Section 11. Products to which the monogram is applied shall be marked per this section. Marking shall be die stamped or paint stenciled or both, as stipulated, unless otherwise agreed on between the purchaser and the manufacturer. The location, size, and sequence of markings shall be as specified in 11.3 and 11.4, except that, at the option of the manufacturer, hot-rolled or hot-stamped markings on pipe and couplings may be substituted for die-stamped markings, and are permitted at intervals along the length. Additional markings, including those for applicable compatible standards, as desired by the manufacturer, or as requested by the purchaser, are not prohibited. Markings shall not overlap; and shall be applied in such manner as not to injure the pipe.



D.2 Drill Pipe Markings

Markings for pipe and methods of application shall be as follows:

D.2.1 MANUFACTURER'S API LICENSE NUMBER (THE MANUFACTURER'S NAME OR MARK IS OPTIONAL)

The manufacturer's API license number shall be die stamped (or paint stenciled, at the option of the manufacturer.)

D.2.2 MONOGRAM AND DATE OF MANUFACTURE

 and the date shall be die stamped unless otherwise agreed on between the purchaser and the manufacturer, in which case it shall be paint stenciled. The  API monogram shall be applied only as specified and only by authorized manufacturers and shall not be applied on any product for which any requirement is indicated to be tentative. The product shall be marked with the date of manufacture defined as the month and year when the monogram is applied. This marking shall be applied in a location immediately following the monogram.

D.2.3 COMPATIBLE STANDARDS

Products in compliance with multiple compatible standards may be stamped or stenciled with the name of each standard (at the option of the manufacturer).

D.2.4 UNFINISHED PIPE

Drill pipe furnished with plain ends or end finishes other than the upsets detailed herein, but having the body of the pipe manufactured in accordance with the requirements specified herein, shall be die stamped with the symbol, UF, immediately following the  monogram, date, and any applicable compatible standards.

D.2.5 DESIGNATION

The size and weight designations are dimensionless quantities based on the former U.S. Customary size and weight per foot.

The size designation (Column 1, Tables 7 and 8) shall be paint stenciled.

The weight designation, as given in Tables 7 and 8, shall be die stamped and paint stenciled.

D.2.6 GRADE

The grade marking shall be die stamped and paint stenciled as follows:

Grade E-75	E
Grade X-95	X
Grade G-105	G
Grade S-135	S

D.3 Stamped Markings

Die-stamped markings shall be placed on the outside surface of the upset portion of either end. The size of die-stamped markings shall be as follows:

Size of Pipe	Size of Markings	
	in.	mm
Pipe 4 and under	$\frac{3}{16}$	4.8
Pipe 4 $\frac{1}{2}$ and over	$\frac{1}{4}$	6.4

The sequence of die-stamped markings shall be as follows:

Manufacturer's API license number	D.2.1
API monogram and date	D.2.2
Compatible Standards	D.2.3
Symbol UF	D.2.4
Weight designation	D.2.5
Grade	D.2.6

Example:

Size 2³/₈, weight 6.65, grade E plain-end drill pipe should be die stamped as follows:

5DXXXX.X  (MO-YR) UF 6.65E

D.4 Paint-Stenciled Markings

Paint-stenciled markings shall be placed on the outside surface of each length of pipe starting not less than 24" (610 mm) from either end of plain-end pipe. The sequence of paint-stenciled markings shall be as follows:

Manufacturer's API license number..... D.2.1
 Size and weight designation..... D.2.5
 Grade..... D.2.6

Example:

Size 5, weight 19.50, grade G-105 drill pipe should be paint stenciled as follows:

5DXXXX.X 5 19.50 G

D.5 Pipe Processor Markings

Pipe that is heat treated by a processor other than the original pipe manufacturer shall be marked as stipulated in D.1, D.2, D.3, and D.4. The processor shall remove any identity which is not indicative of the new condition of the product as a result of heat treating (i.e., prior grade identity, original pipe manufacturer's name or logo).

APPENDIX M—METRIC CONVERSION PROCEDURE

The following procedures were used to make the soft metric conversion of U.S. Customary units to SI units in the metric conversion of API Spec 5D.

M.1 FRACTIONS

Fractions and numbers with fractions in U.S. Customary units were converted to the full decimal equivalent in U.S. Customary numbers in inches without rounding, and the full decimal equivalent in U.S. Customary numbers were then converted to SI values using the following formula:

$$N_m = 25.4 \bullet N$$

where

N_m = The SI equivalent of an inch fraction, mm,

N = The full decimal equivalent of a U.S. Customary fraction which has not been rounded, in.

The SI equivalent of inch fractions were then rounded to the appropriate number of places in mm.

M.2 OUTSIDE DIAMETER

The U.S. Customary values for outside diameters of pipe and couplings were converted to SI values using the following formula:

$$D_m = 25.4 \bullet D$$

where

D_m = SI outside diameter, mm,

D = outside diameter, in.

The SI outside diameters of pipe and couplings smaller were rounded to the nearest 0.01 mm.

M.3 WALL THICKNESS

The U.S. Customary values for wall thickness were converted to SI values using the following formula:

$$t_m = 25.4 \bullet t$$

where

t_m = SI wall thickness, mm,

t = wall thickness, in.

The SI wall thickness' were rounded to the nearest 0.1 mm.

M.4 INSIDE DIAMETER

The SI inside diameters of pipe were calculated (not converted) using the following formula:

$$d_m = D_m - 2 \bullet t_m$$

where

d_m = SI inside diameter, mm,

D_m = SI outside diameter, mm,

t_m = SI wall thickness, mm.

The SI inside diameters were rounded to the nearest 0.01 mm.

M.5 DRIFT DIAMETER

The SI inside diameters of pipe were calculated (not converted) using the following formula:

$$dd_m = d_m - dc_m$$

where

dd_m = SI drift diameter, mm,

d_m = SI inside diameter, mm,

dc_m = SI drift constant, see Table 8, mm.

The SI drift diameters were rounded to the nearest 0.01 mm.

M.6 DIAMETERS AND LENGTHS OF UPSETS

The U.S. Customary values for the diameters and lengths of upsets were converted to SI values using the following formula:

$$X_m = 25.4 \bullet X$$

where

X_m = SI upset dimensions, mm,

X = upset dimension, in.

The SI diameters and lengths of upsets were rounded to the nearest 0.1 mm.

M.7 PLAIN END LINEAR DENSITY

The SI plain end linear densities were calculated (not converted) using the following formula:

$$P_l = 0.0246615(D_m - t_m)t_m$$

where

P_l = SI plain end linear density, kg/m,

D_m = SI outside diameter, mm,

t_m = SI wall thickness, mm.

The SI plain end linear densities are rounded to the nearest 0.01 kg/m.

M.8 YIELD STRENGTH AND TENSILE STRENGTH

The U.S. Customary values for yielded strength and tensile strength were converted to SI values using the following formula:

$$ys_m = 0.00689476 \cdot ys$$

$$ts_m = 0.00689476 \cdot ts$$

where

ts_m = SI tensile strength, MPa,

ts = tensile strength, psi,

ys_m = SI yield strength, MPa,

ys = yield Strength, psi.

The converted SI strengths were rounded to the nearest 1 MPa.

M.9 TEMPERATURE

The U.S. Customary temperatures in degrees Fahrenheit were converted to SI temperature in degrees Celsius using the following formula:

$$^{\circ}\text{C} = \frac{5}{9} (^{\circ}\text{F} - 32)$$

where

$^{\circ}\text{C}$ = SI temperature, degrees Celsius,

$^{\circ}\text{F}$ = temperature, degrees Fahrenheit.

The SI temperatures were rounded to the nearest 1 $^{\circ}\text{C}$.

M.10 CHARPY IMPACT ENERGY

The U.S. customary values for impact energy were converted to SI values using the following formula:

$$E_m = 1.35582 \cdot E$$

where

E_m = SI Charpy impact energy in joules,

E = Charpy impact energy in foot-pounds.

The Si energy values were rounded to the nearest 1 joule.

API Related Publications Order Form

Date: _____
(Month, Day, Year)

API Member
(Check if Yes)

Invoice To – Check here if same as “Ship To”

Ship To – (UPS will not deliver to a P.O. Box)

Company: _____

Company: _____

Name/Dept.: _____

Name/Dept.: _____

Address: _____

Address: _____

City: _____ State/Province: _____

City: _____ State/Province: _____

Zip: _____ Country: _____

Zip: _____ Country: _____

Customer Daytime Telephone No.: _____

Customer Daytime Telephone No.: _____

Fax No.: _____

Fax No.: _____

(Essential for Foreign Orders)

(Essential for Foreign Orders)

Payment Enclosed \$ _____

Please Bill Me

Payment By Charge Account:

P.O. No.: _____

MasterCard Visa American Express

Customer Account No.: _____

Account No.: _____

Name (As It Appears on Card): _____

Expiration Date: _____

Signature: _____

State Sales Tax – The American Petroleum Institute is required to collect sales tax on publications mailed to the following states: AL, AR, CT, DC, FL, GA, IL, IN, IA, KS, KY, ME, MD, MA, MI, MN, MO, NE, NI, NY, NC, ND, OH, PA, RI, SC, TN, TX, VT, VA, WV and WI. Prepayment of orders shipped to these states should include applicable sales tax unless a purchaser is exempt. If exempt, please print your state exemption number and enclose a copy of the current exemption certificate.

Exemption Number: _____ State: _____

Quantity	Order Number	Title	SO*	Unit Price	Total
	G07039	Spec 7, Rotary Drill Stem Elements		\$ 115.00	
	G05CT6	Spec 5CT, Casing and Tubing (U.S. Customary Units)		\$ 125.00	
	G05L41	Spec 5L, Line Pipe		\$ 125.00	
	G05B14	Spec 5B, Threading, Gauging and Thread Inspection of Casing, Tubing, and Line Pipe Threads		\$ 100.00	
	G05A31	RP 5A3, Thread Compounds for Casing, Tubing, and Line Pipe		\$ 80.00	
	G05A56	RP 5A5, Field Inspection of New Casing, Tubing, and Plain-End Drill Pipe		\$ 100.00	

Shipping and Handling – All orders are shipped via UPS or First Class Mail in the U.S. and Canada. Orders to all other countries will be sent by Airmail. U.S. and Canada, \$5 per order handling fee, plus actual shipping costs. All other countries, for Airmail (standard service) add 25% of order value. All other countries, for UPS Next Day, add an additional 10% of order value.

Rush Shipping Charge – FedEx, \$10 in addition to customer providing FedEx account number: _____ UPS Next Day, \$10 plus the actual shipping costs (1-9 items). UPS Second Day, add \$10 plus the actual shipping costs (1-9 items).

Rush Bulk Orders – 1-9 items, \$10. Over 9 items, add \$1 each for every additional item. *NOTE: Shipping on foreign orders cannot be rushed without FedEx account number.*

Returns Policy - Only publications received in damaged condition or as a result of shipping or processing errors, if unstamped and otherwise not defaced, may be returned for replacement within 45 days of the initiating invoice date. A copy of the initiating invoice must accompany each return. Material which has neither been damaged in shipment nor shipped in error requires prior authorization and may be subject to a shipping and handling charge. **All returns must be shipped prepaid using third class postage. If returns are due to processing or shipping errors, API will refund the third class postage.**

Subtotal
State Sales Tax (see above)
Rush Shipping Charge (see left)
Shipping and Handling (see left)
Total (in U.S. Dollars)

*To be placed on Standing Order for future editions of this publication, place a check mark in the space provided.

Pricing and availability subject to change without notice.

Mail Orders: American Petroleum Institute, Order Desk, 1220 L Street, N.W., Washington, DC 20005-4070
Fax Orders: (202) 962-4776 Phone Orders: (202) 682-8375

To better serve you, please refer to this code when ordering: L A 4 4 4 8 0 1 9 9

The American Petroleum Institute provides additional resources and programs to industry which are based on API Standards. For more information, contact:

- Training/Workshops Ph: 202-682-8490
Fax: 202-682-8222
- Inspector Certification Programs Ph: 202-682-8161
Fax: 202-962-4739
- American Petroleum Institute
Quality Registrar Ph: 202-682-8130
Fax: 202-682-8070
- Monogram Program Ph: 202-962-4791
Fax: 202-682-8070
- Engine Oil Licensing and
Certification System Ph: 202-682-8233
Fax: 202-962-4739
- Petroleum Test Laboratory
Accreditation Program Ph: 202-682-8129
Fax: 202-682-8070

In addition, petroleum industry technical, patent, and business information is available online through API EnCompass™. Call 1-888-604-1880 (toll-free) or 212-366-4040, or fax 212-366-4298 to discover more.

To obtain a free copy of the API Publications, Programs, and Services Catalog, call 202-682-8375 or fax your request to 202-962-4776. Or see the online interactive version of the catalog on our web site at www.api.org/cat.



**American
Petroleum
Institute**

**Helping You
Get The Job
Done Right.™**

Additional copies available from API Publications and Distribution:
(202) 682-8375

Information about API Publications, Programs and Services is
available on the World Wide Web at: <http://www.api.org>



1220 L Street, Northwest
Washington, D.C. 20005-4070
202-682-8000

Order No. G05D04